

# *Synchronizing Strongly Connected Digraphs*

M. V. Volkov

Ural State University, Ekaterinburg, Russia



## ***New Perspectives***

---

Yesterday Avraham Trahtman has presented his brilliant solution to the Road Coloring Conjecture.

Yesterday Avraham Trahtman has presented his brilliant solution to the Road Coloring Conjecture. Thus, every strongly connected primitive digraph with constant out-degree has a synchronizing coloring.

Yesterday Avraham Trahtman has presented his brilliant solution to the Road Coloring Conjecture. Thus, every strongly connected primitive digraph with constant out-degree has a synchronizing coloring.

This means that now we can address **many questions** previously studied for synchronizing automata to strongly connected primitive digraph with constant out-degree.

Yesterday Avraham Trahtman has presented his brilliant solution to the Road Coloring Conjecture. Thus, every strongly connected primitive digraph with constant out-degree has a synchronizing coloring.

This means that now we can address **many questions** previously studied for synchronizing automata to strongly connected primitive digraph with constant out-degree. It creates a unique opportunity for new developments in the area and also may shed some new light on longstanding open problems.

# *A Random Example*

---

- Complexity of calculating short reset word for automata:

# *A Random Example*

---

- Complexity of calculating short reset word for automata: given a DFA  $\mathcal{A}$  and a positive integer  $n$ , is there a reset word of length  $n$  for  $\mathcal{A}$ ?

# *A Random Example*

---

- Complexity of calculating short reset word for automata: given a DFA  $\mathcal{A}$  and a positive integer  $n$ , is there a reset word of length  $n$  for  $\mathcal{A}$ ? Known to be NP-complete.

# *A Random Example*

---

- Complexity of calculating short reset word for automata: given a DFA  $\mathcal{A}$  and a positive integer  $n$ , is there a reset word of length  $n$  for  $\mathcal{A}$ ? Known to be NP-complete.
- Complexity of calculating short reset word for **graphs**:

# A Random Example

---

- Complexity of calculating short reset word for automata: given a DFA  $\mathcal{A}$  and a positive integer  $n$ , is there a reset word of length  $n$  for  $\mathcal{A}$ ? Known to be NP-complete.
- Complexity of calculating short reset word for **graphs**: given a strongly connected primitive digraph  $\Gamma$  with constant out-degree and a positive integer  $n$ , is there a reset word of length  $n$  for a synchronizing coloring of  $\Gamma$ ?

# *A Random Example*

---

- Complexity of calculating short reset word for automata: given a DFA  $\mathcal{A}$  and a positive integer  $n$ , is there a reset word of length  $n$  for  $\mathcal{A}$ ? Known to be NP-complete.
- Complexity of calculating short reset word for **graphs**: given a strongly connected primitive digraph  $\Gamma$  with constant out-degree and a positive integer  $n$ , is there a reset word of length  $n$  for a synchronizing coloring of  $\Gamma$ ? Clearly is in NP but may even be in P.

- The Černý Conjecture:

- The Černý Conjecture: is it true that, for any synchronizing automaton with  $n$  states, there exists a reset word of length  $(n - 1)^2$ ?

# Hybrid Problem

---

- The Černý Conjecture: is it true that, for any synchronizing automaton with  $n$  states, there exists a reset word of length  $(n - 1)^2$ ?
- The hybrid Černý/Road Coloring problem.

- The Černý Conjecture: is it true that, for any synchronizing automaton with  $n$  states, there exists a reset word of length  $(n - 1)^2$ ?
- The **hybrid Černý/Road Coloring problem**. Let  $\Gamma$  be a strongly connected primitive digraph with constant out-degree and  $n$  vertices. What is the minimum length of reset words for synchronizing colorings of  $\Gamma$ ?

- The Černý Conjecture: is it true that, for any synchronizing automaton with  $n$  states, there exists a reset word of length  $(n - 1)^2$ ?
- The **hybrid Černý/Road Coloring problem**. Let  $\Gamma$  be a strongly connected primitive digraph with constant out-degree and  $n$  vertices. What is the minimum length of reset words for synchronizing colorings of  $\Gamma$ ?

For instance, the Černý automata  $\mathcal{C}_n$ ,  $n = 2, 3, \dots$ , admit synchronizing recolorings with pretty short reset words, as already mentioned in Trahtman's lecture.

# Černý Automata

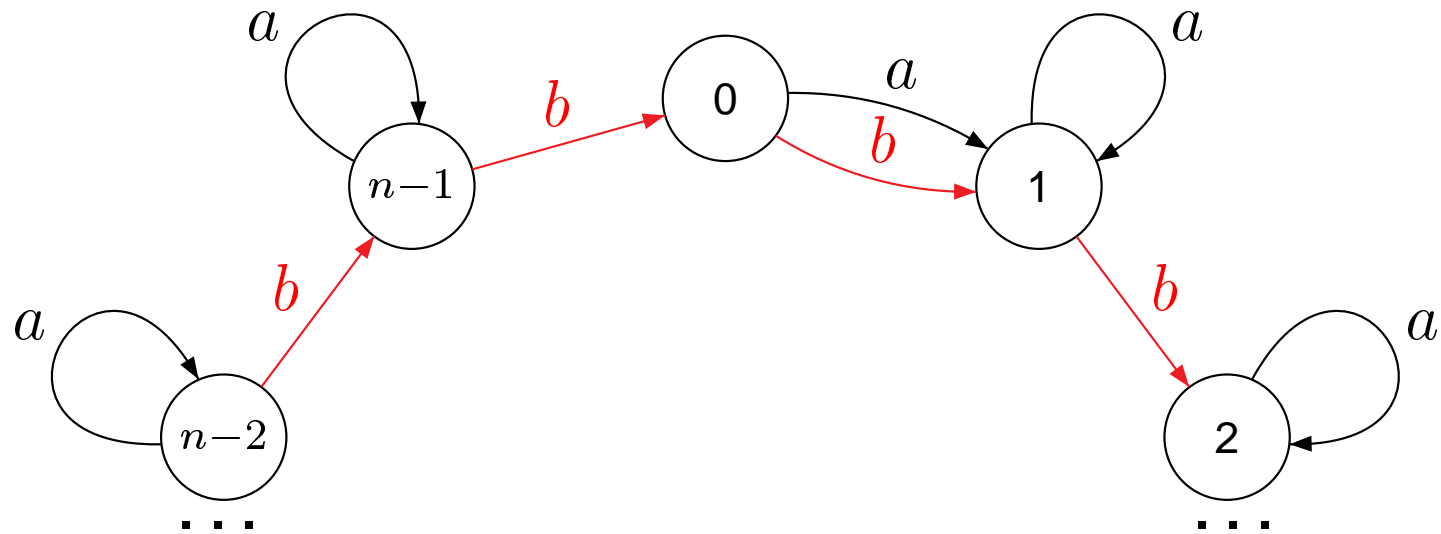

Recall that the states of  $\mathcal{C}_n$  are the residues modulo  $n$ , the input letters  $a$  and  $b$  act as follows:  $\delta(0, a) = 1$ ,  $\delta(m, a) = m$  for  $0 < m < n$ ,  $\delta(m, b) = m+1 \pmod{n}$ .

# Černý Automata

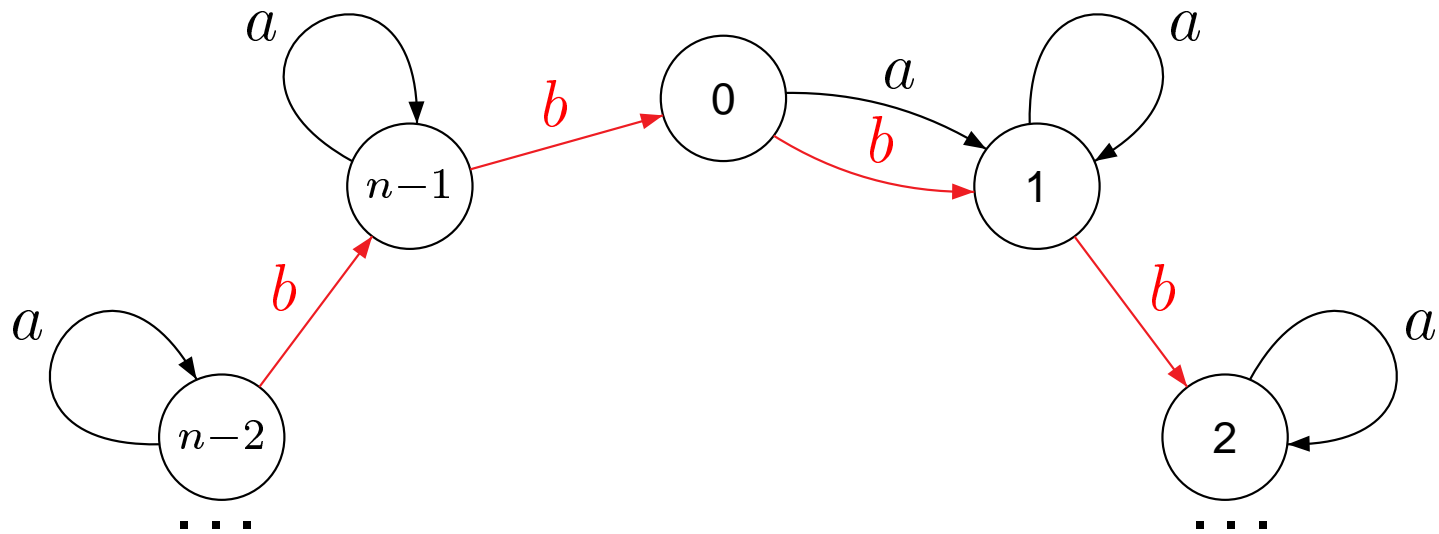

Recall that the states of  $\mathcal{C}_n$  are the residues modulo  $n$ , the input letters  $a$  and  $b$  act as follows:  $\delta(0, a) = 1$ ,  $\delta(m, a) = m$  for  $0 < m < n$ ,  $\delta(m, b) = m+1 \pmod{n}$ . Černý has proved that the shortest reset word for  $\mathcal{C}_n$  is  $(ab^{n-1})^{n-2}a$  of length  $(n-1)^2$ .

# Černý Automata

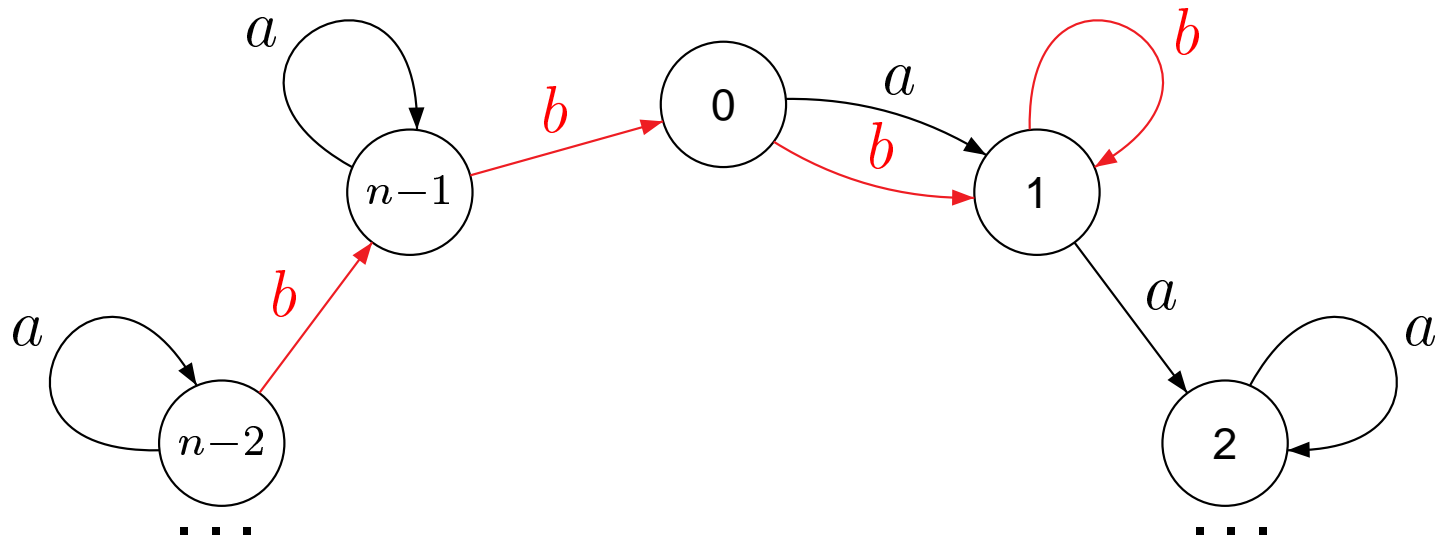

Recall that the states of  $\mathcal{C}_n$  are the residues modulo  $n$ , the input letters  $a$  and  $b$  act as follows:  $\delta(0, a) = 1$ ,  $\delta(m, a) = m$  for  $0 < m < n$ ,  $\delta(m, b) = m+1 \pmod{n}$ .

Černý has proved that the shortest reset word for  $\mathcal{C}_n$  is  $(ab^{n-1})^{n-2}a$  of length  $(n-1)^2$ .

However, one can recolor the same graph as shown in the picture, and the recolored automaton is reset by the word  $b^{n-1}$ .

# *Hybrid Problem*

---

As Trahtman mentioned, all known examples of automata reaching the Černý bound admit a recoloring with short reset words.

## *Hybrid Problem*

---

As Trahtman mentioned, all known examples of automata reaching the Černý bound admit a recoloring with short reset words. (A synchronizing automaton with  $n$  states *reaches the Černý bound* if the minimum length of its reset words is  $(n - 1)^2$ .)

# Hybrid Problem

---

As Trahtman mentioned, all known examples of automata reaching the Černý bound admit a recoloring with short reset words. (A synchronizing automaton with  $n$  states *reaches the Černý bound* if the minimum length of its reset words is  $(n - 1)^2$ .)

We present here all known proper synchronizing automata beyond the Černý series  $\mathcal{C}_n$ ,  $n = 3, 4, \dots$ , that reach the Černý bound.

# Hybrid Problem

As Trahtman mentioned, all known examples of automata reaching the Černý bound admit a recoloring with short reset words. (A synchronizing automaton with  $n$  states *reaches the Černý bound* if the minimum length of its reset words is  $(n - 1)^2$ .)

We present here all known proper synchronizing automata beyond the Černý series  $\mathcal{C}_n$ ,  $n = 3, 4, \dots$ , that reach the Černý bound. (A synchronizing automaton  $\mathcal{A} = \langle Q, \Sigma, \delta \rangle$  is *proper* if none of the automata obtained from  $\mathcal{A}$  by erasing any letter in  $\Sigma$  are synchronizing.)

# *Sporadic Examples*

---

For  $n = 3$  we have three sporadic automata:

# Sporadic Examples

For  $n = 3$  we have three sporadic automata:

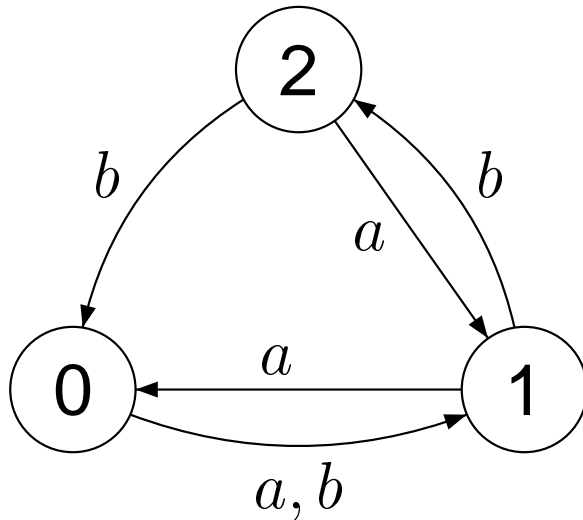

# Sporadic Examples

For  $n = 3$  we have three sporadic automata:

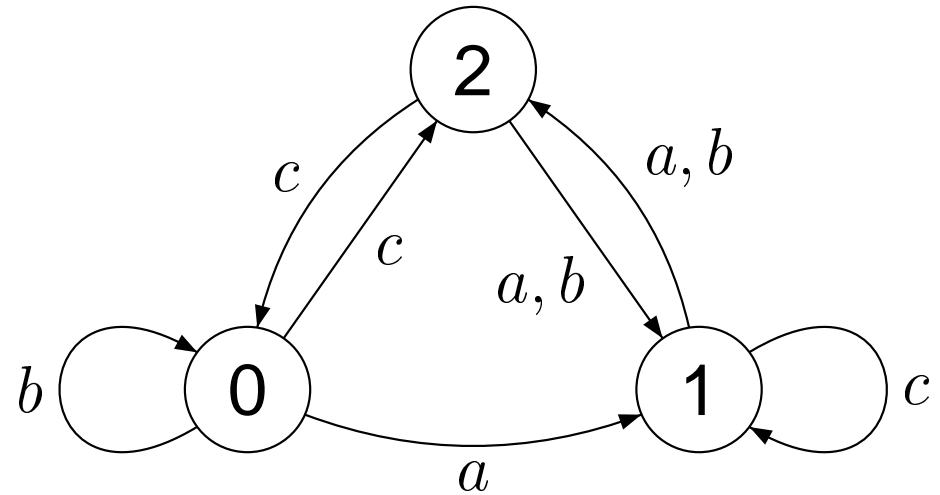
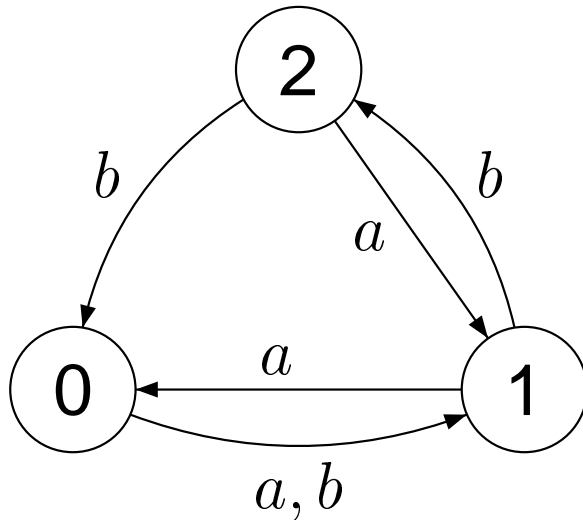

# Sporadic Examples

For  $n = 3$  we have three sporadic automata:

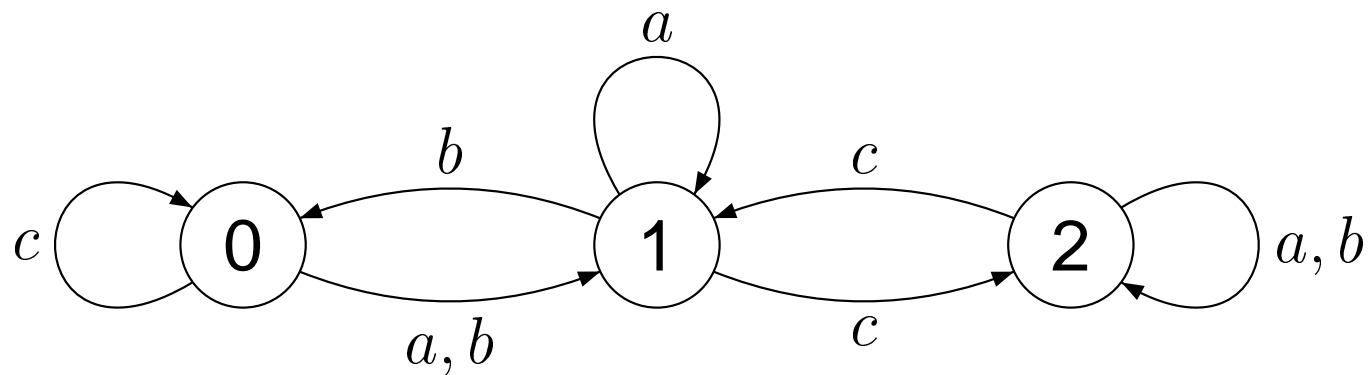
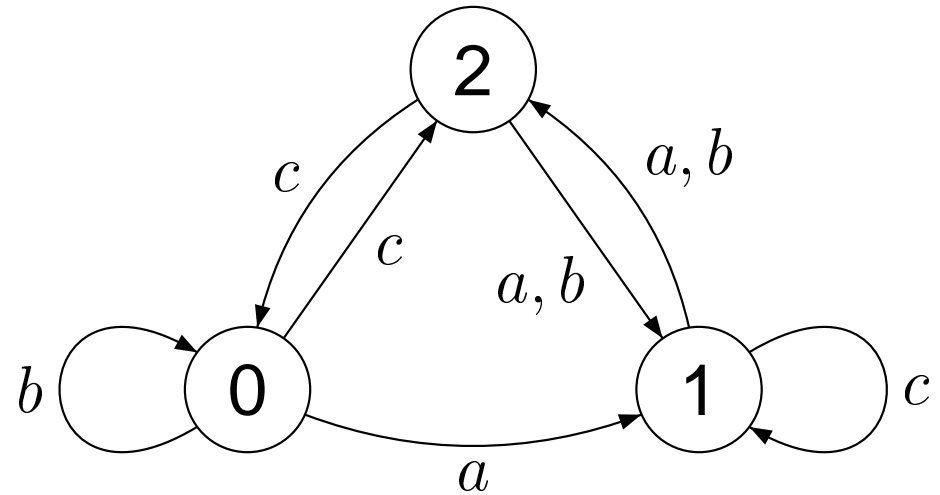
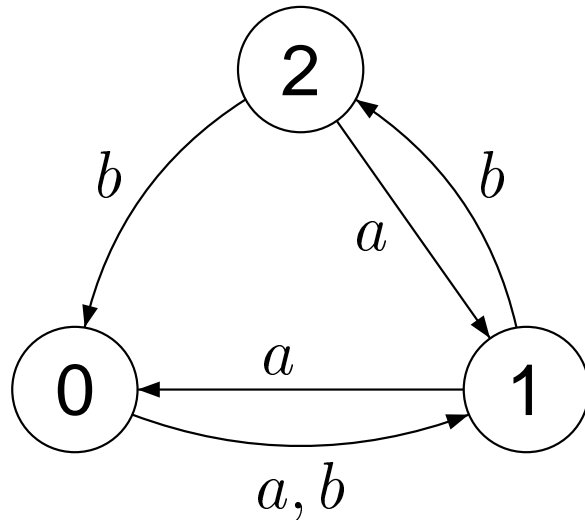

# Sporadic Examples

For  $n = 3$  we have three sporadic automata:

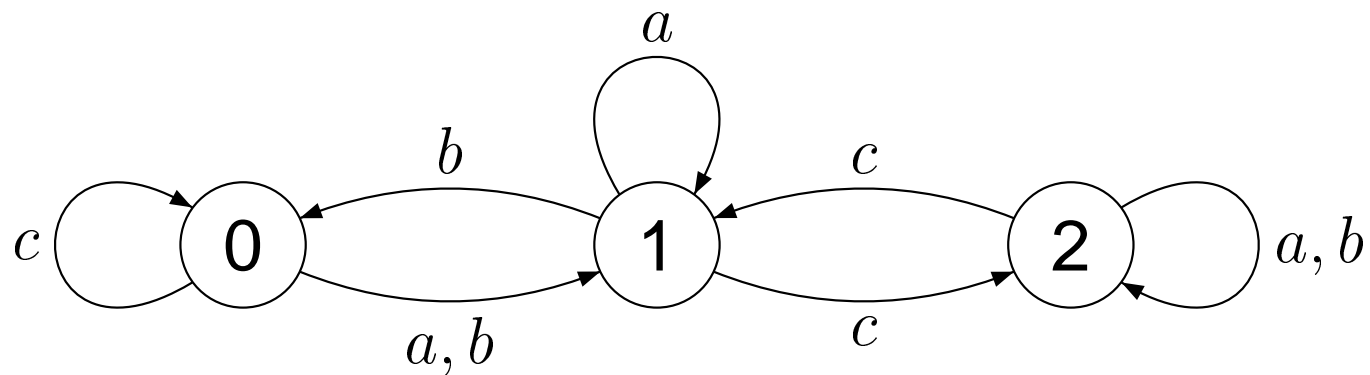
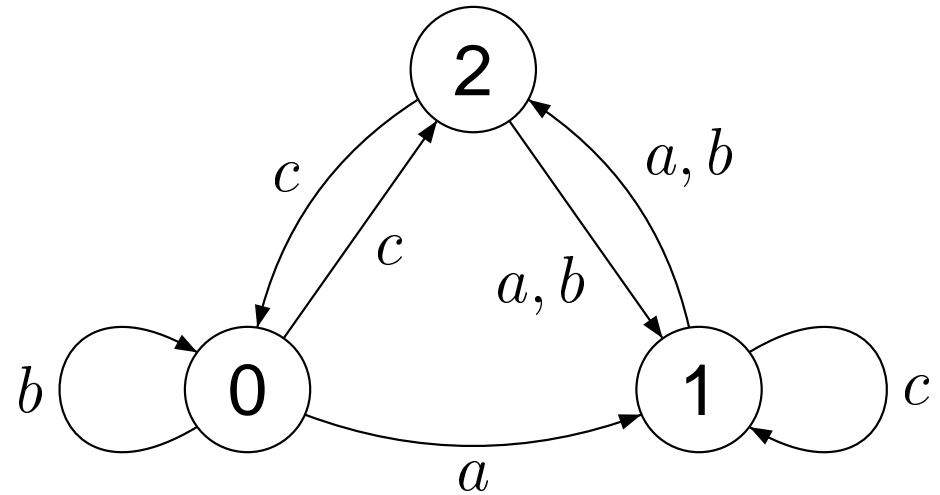
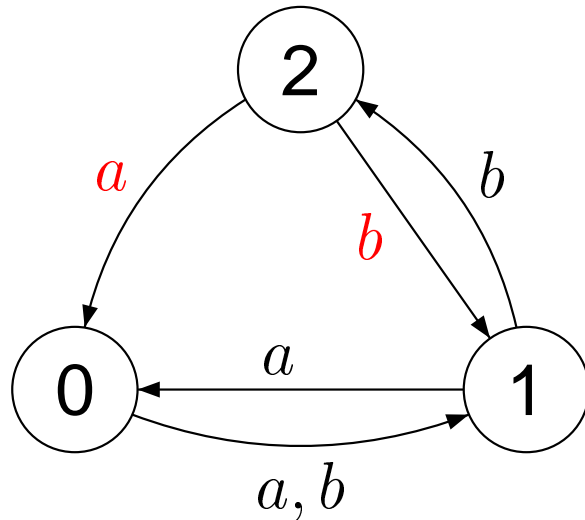

# *Sporadic Examples*

---

Also for  $n = 4$  three sporadic automata are known:

# Sporadic Examples

Also for  $n = 4$  three sporadic automata are known:

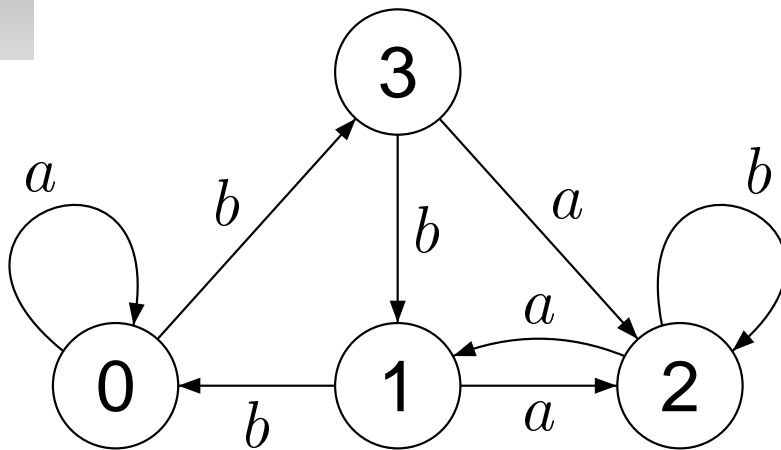

# Sporadic Examples

Also for  $n = 4$  three sporadic automata are known:

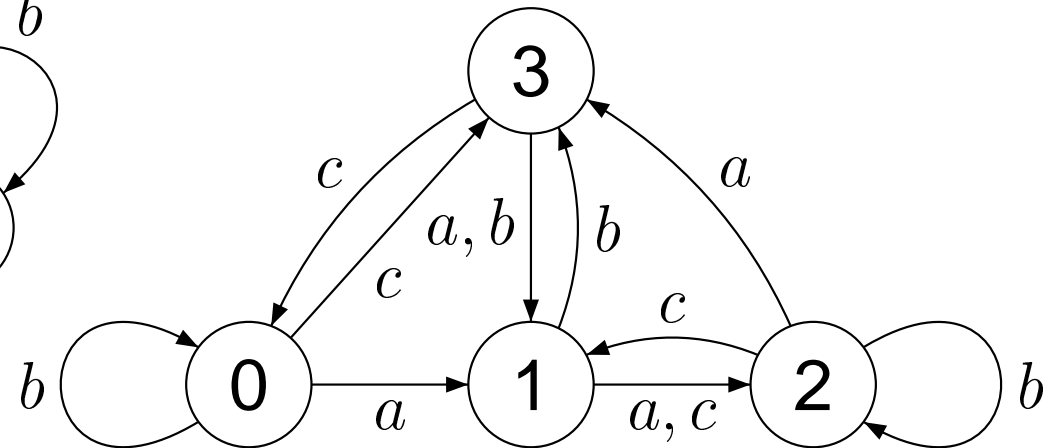
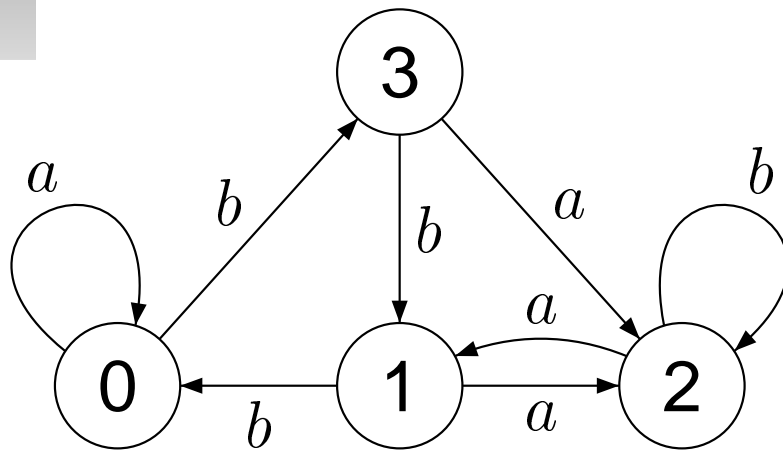

# Sporadic Examples

Also for  $n = 4$  three sporadic automata are known:

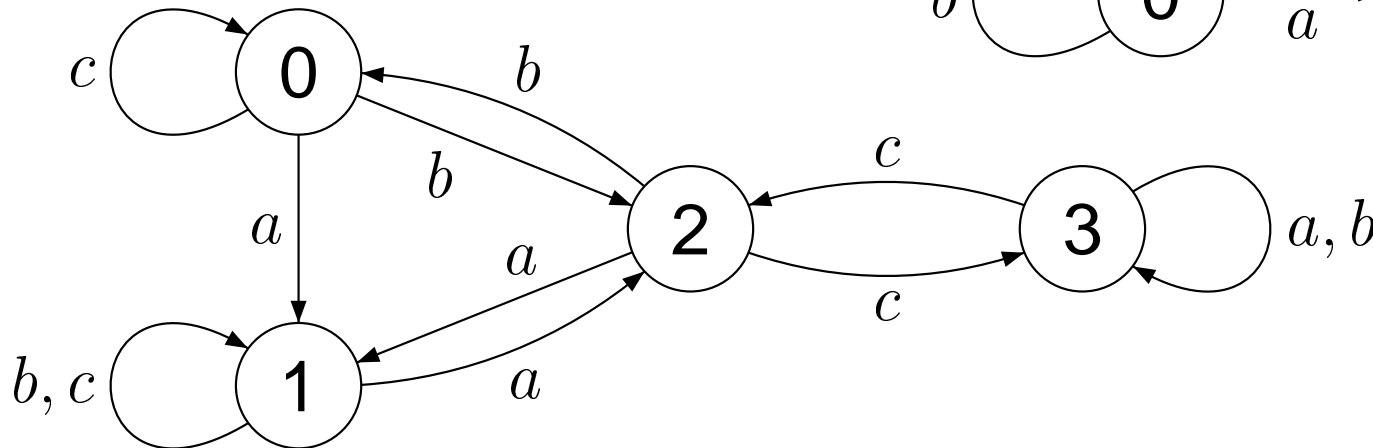
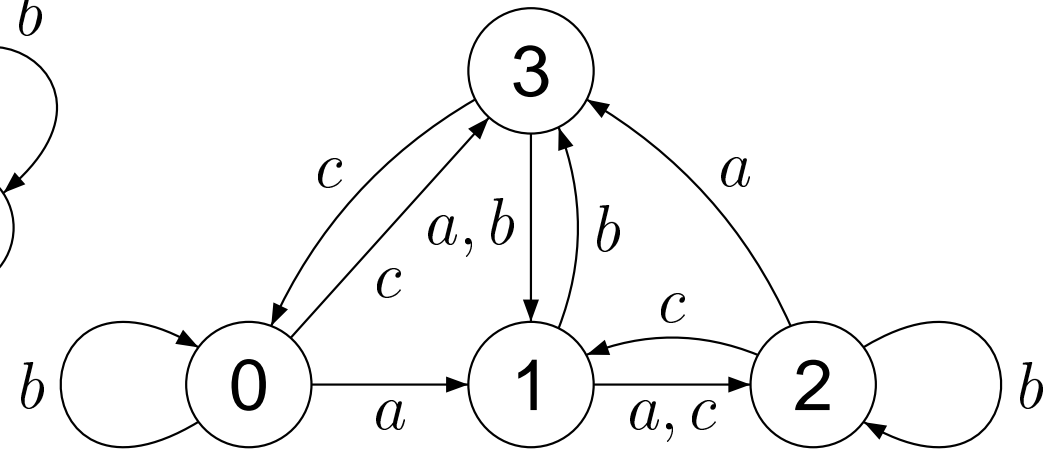
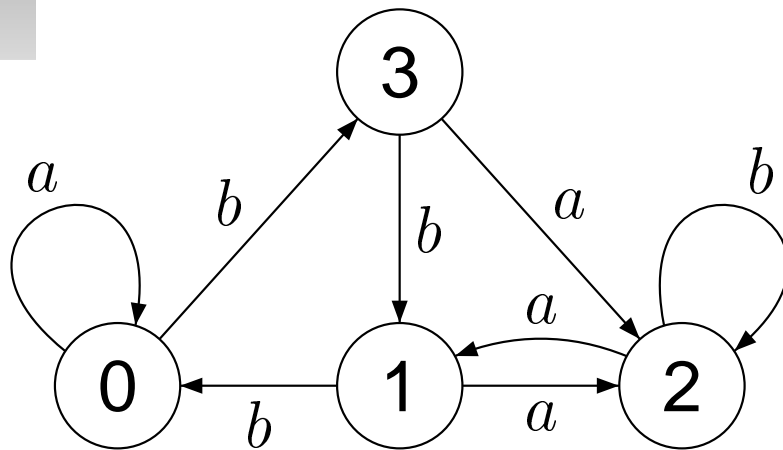

# *Sporadic Examples*

---

A proper 5-state automaton reaching the Černý bound has been recently discovered by Adam Roman.

# Sporadic Examples

A proper 5-state automaton reaching the Černý bound has been recently discovered by Adam Roman.

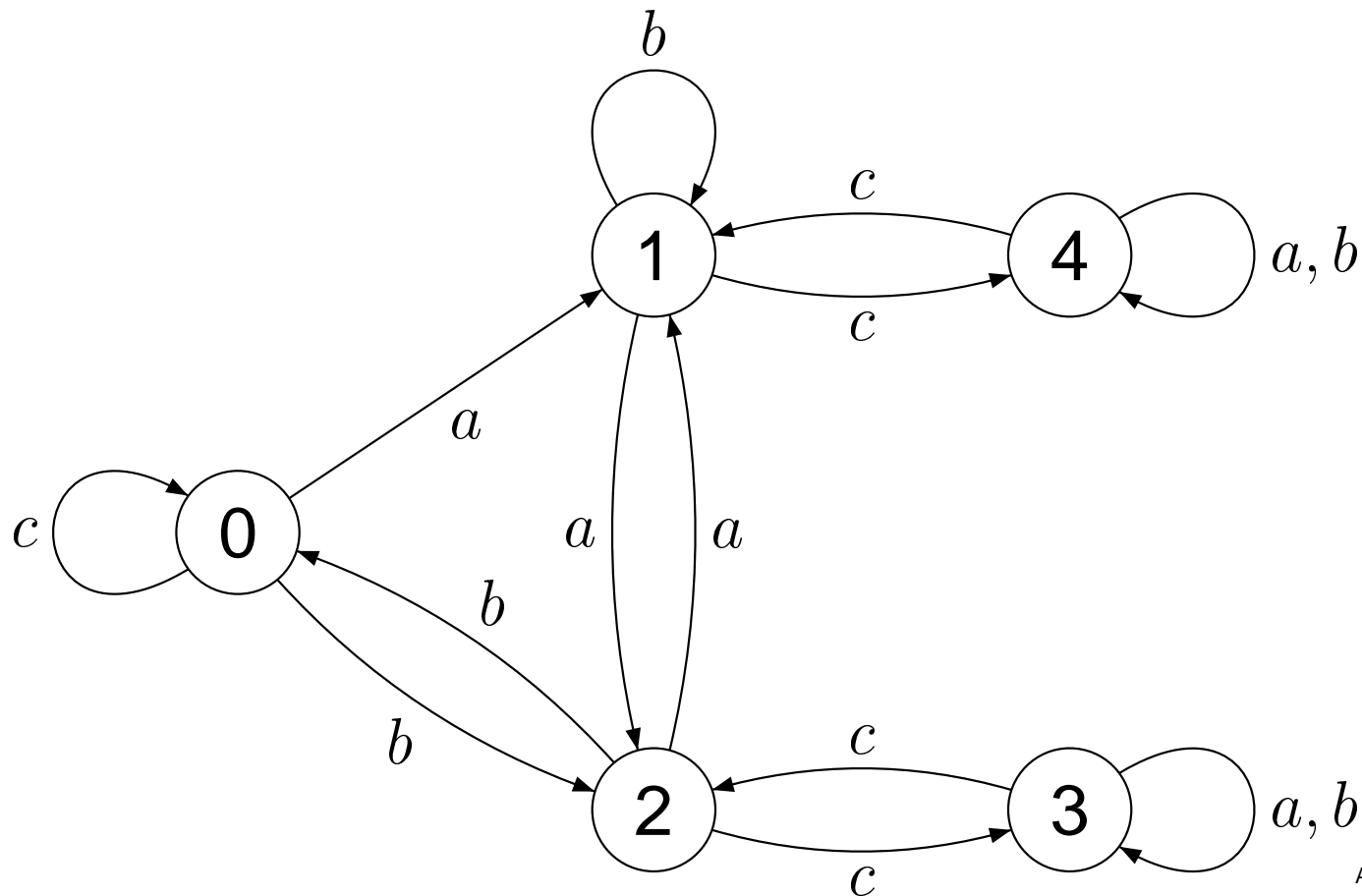

## *Kari's Example*

---

The last in our list and the most remarkable example was published in 2001 by Jarkko Kari (A counter example to a conjecture concerning synchronizing words in finite automata, EATCS Bull., 73, 146).

# Kari's Example

The last in our list and the most remarkable example was published in 2001 by Jarkko Kari (A counter example to a conjecture concerning synchronizing words in finite automata, EATCS Bull., 73, 146).

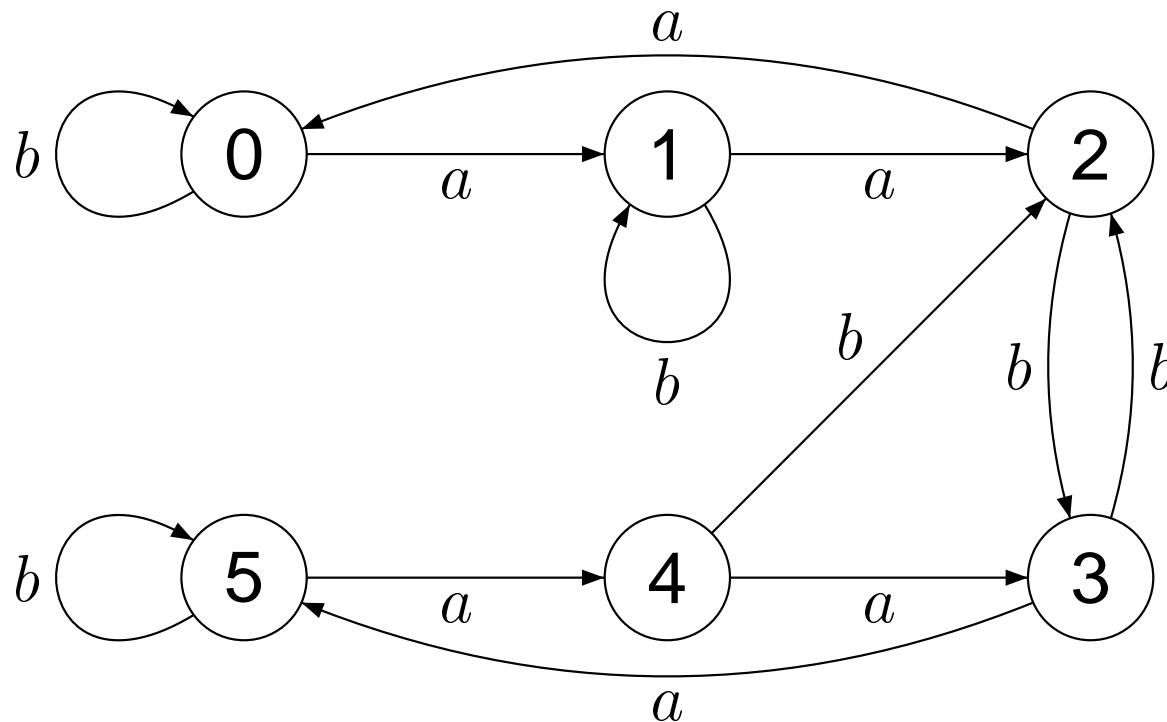

Thus, we see that every known synchronizing automaton with  $n$  states which reaches the Černý bound admits a synchronizing recoloring with a reset word of length  $n - 1$ .

Thus, we see that every known synchronizing automaton with  $n$  states which reaches the Černý bound admits a synchronizing recoloring with a reset word of length  $n - 1$ . Does the same conclusion hold true for **every** synchronizing automaton with  $n$  states?

## *Hybrid problem*

---

Thus, we see that every known synchronizing automaton with  $n$  states which reaches the Černý bound admits a synchronizing recoloring with a reset word of length  $n - 1$ . Does the same conclusion hold true for **every** synchronizing automaton with  $n$  states? In other words, does every strongly connected primitive digraph with constant out-degree and  $n$  vertices admit a synchronizing coloring with a reset word of length  $n - 1$ ?

Thus, we see that every known synchronizing automaton with  $n$  states which reaches the Černý bound admits a synchronizing recoloring with a reset word of length  $n - 1$ . Does the same conclusion hold true for **every** synchronizing automaton with  $n$  states? In other words, does every strongly connected primitive digraph with constant out-degree and  $n$  vertices admit a synchronizing coloring with a reset word of length  $n - 1$ ?

**No**, a counterexample follows.

# Ananichev's Example

Consider the following digraph:

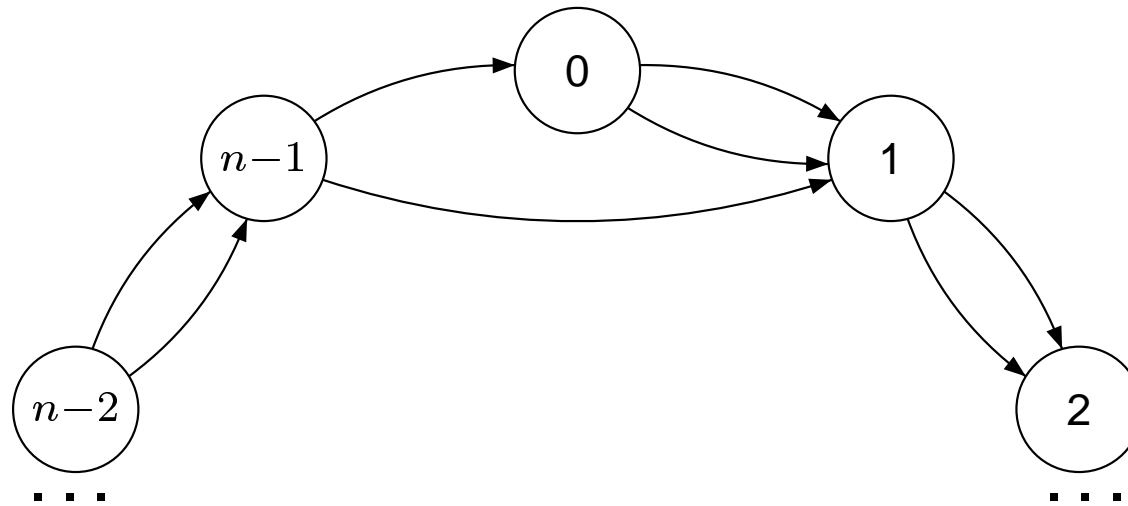

# Ananichev's Example

Consider the following digraph:

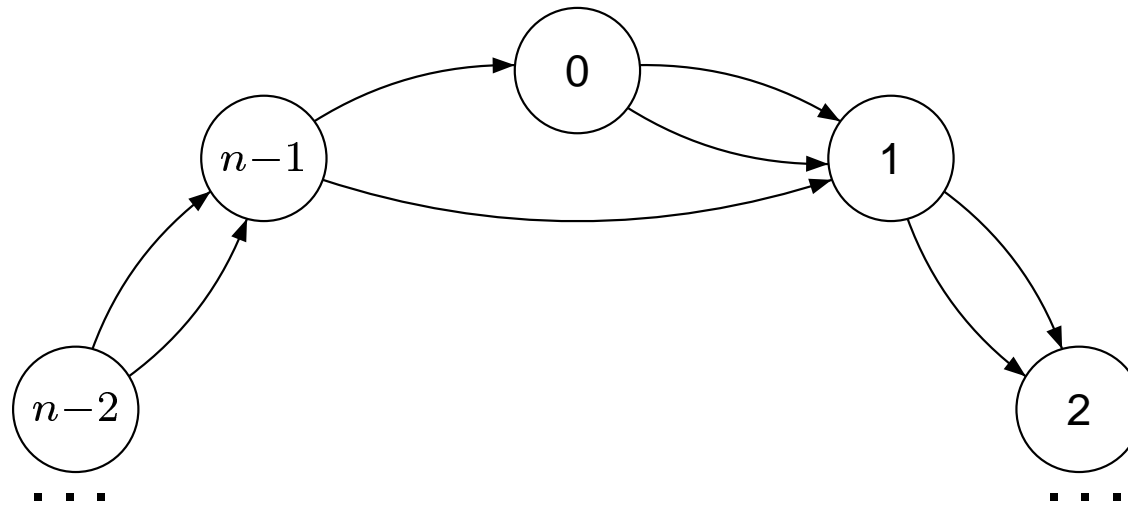

Obviously, it is strongly connected and primitive, and each vertex has out-degree 2.

# Ananichev's Example

Consider the following digraph:

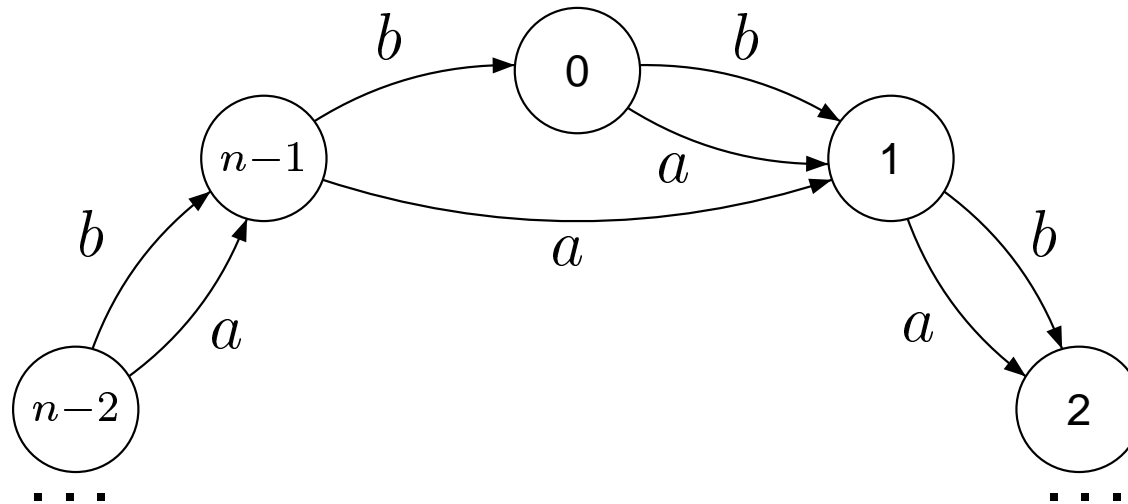

Obviously, it is strongly connected and primitive, and each vertex has out-degree 2. It is also clear that up to renaming letters the digraph has only one coloring.

# Ananichev's Example

Consider the following digraph:

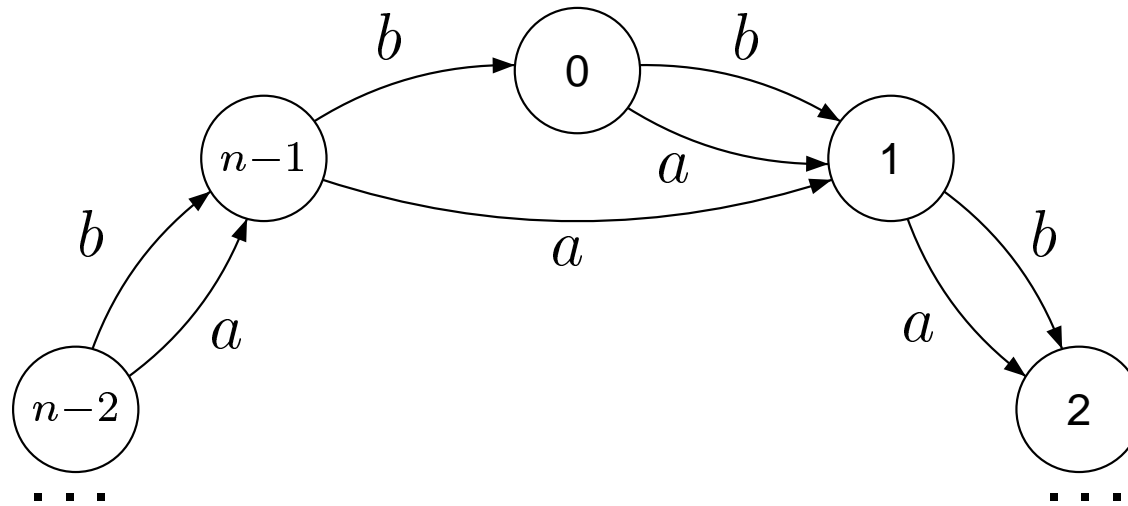

Obviously, it is strongly connected and primitive, and each vertex has out-degree 2. It is also clear that up to renaming letters the digraph has only one coloring. By Trahtman's theorem this coloring must be synchronizing.

# Ananichev's Example

Consider the following digraph:

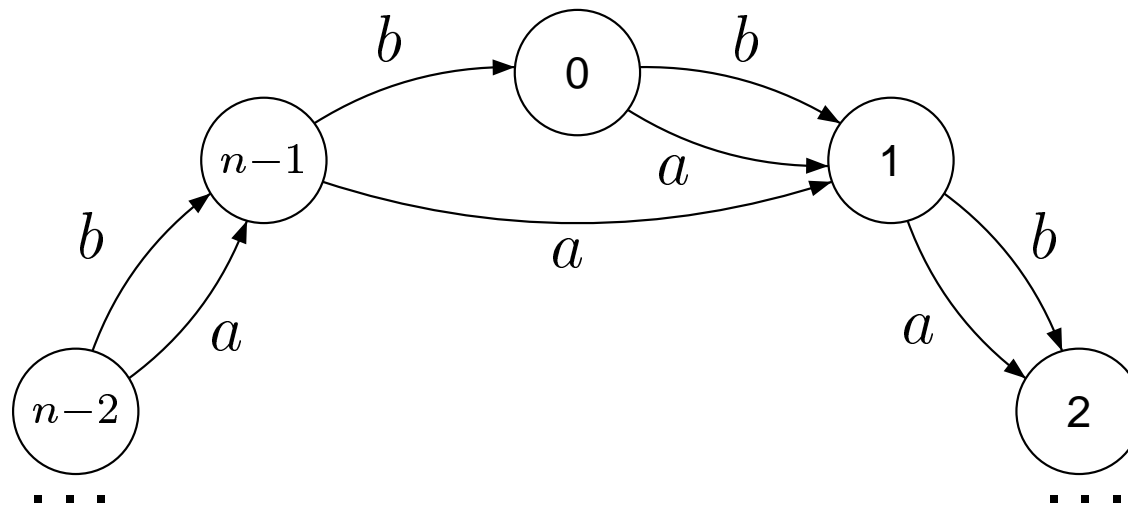

Obviously, it is strongly connected and primitive, and each vertex has out-degree 2. It is also clear that up to renaming letters the digraph has only one coloring. By Trahtman's theorem this coloring must be synchronizing. But what is the minimum length of reset words?

## *Ananichev's Example*

---

The answer is  $n^2 - 3n + 3 = (n - 1)(n - 2) + 1$  and there is a unique reset word of this length, namely,  $(ab^{n-2})^{n-2}a$ .

## *Ananichev's Example*

---

The answer is  $n^2 - 3n + 3 = (n - 1)(n - 2) + 1$  and there is a unique reset word of this length, namely,  $(ab^{n-2})^{n-2}a$ . The proof that there are no shorter reset words is surprisingly difficult.

# *Ananichev's Example*

---

The answer is  $n^2 - 3n + 3 = (n - 1)(n - 2) + 1$  and there is a unique reset word of this length, namely,  $(ab^{n-2})^{n-2}a$ . The proof that there are no shorter reset words is surprisingly difficult. It is achieved through a game-theoretic method developed in several papers by Ananichev, myself and our students.

# Ananichev's Example

---

The answer is  $n^2 - 3n + 3 = (n - 1)(n - 2) + 1$  and there is a unique reset word of this length, namely,  $(ab^{n-2})^{n-2}a$ . The proof that there are no shorter reset words is surprisingly difficult. It is achieved through a game-theoretic method developed in several papers by Ananichev, myself and our students.

Here I shall illustrate this method on a simpler example.

# Ananichev's Example

The answer is  $n^2 - 3n + 3 = (n - 1)(n - 2) + 1$  and there is a unique reset word of this length, namely,  $(ab^{n-2})^{n-2}a$ . The proof that there are no shorter reset words is surprisingly difficult. It is achieved through a game-theoretic method developed in several papers by Ananichev, myself and our students.

Here I shall illustrate this method on a simpler example. Namely, I shall prove that the minimum length of reset words for the Černý automaton  $\mathcal{C}_n$  is  $(n - 1)^2$ .

We use a **solitaire-like game**:

We use a **solitaire-like game**:

- The digraph of  $\mathcal{C}_n$  — the **game-board**.

We use a **solitaire-like game**:

- The digraph of  $\mathcal{C}_n$  — the **game-board**.
- The **initial position** — each state holds a coin, all coins are pairwise distinct.

We use a **solitaire-like game**:

- The digraph of  $\mathcal{C}_n$  — the **game-board**.
- The **initial position** — each state holds a coin, all coins are pairwise distinct.
- Each letter  $c \in \{a, b\}$  defines a **move** — coins slide along the arrows labelled  $c$  and, whenever two coins meet at the state 1, the coin arriving from 0 is removed.

We use a **solitaire-like game**:

- The digraph of  $\mathcal{C}_n$  — the **game-board**.
- The **initial position** — each state holds a coin, all coins are pairwise distinct.
- Each letter  $c \in \{a, b\}$  defines a **move** — coins slide along the arrows labelled  $c$  and, whenever two coins meet at the state 1, the coin arriving from 0 is removed.
- The **goal** — to free all but one states.

We use a **solitaire-like game**:

- The digraph of  $\mathcal{C}_n$  — the **game-board**.
- The **initial position** — each state holds a coin, all coins are pairwise distinct.
- Each letter  $c \in \{a, b\}$  defines a **move** — coins slide along the arrows labelled  $c$  and, whenever two coins meet at the state 1, the coin arriving from 0 is removed.
- The **goal** — to free all but one states.
- The only coin that remains at the end of the game is the **golden** coin  $G$ .

# Černý Automata

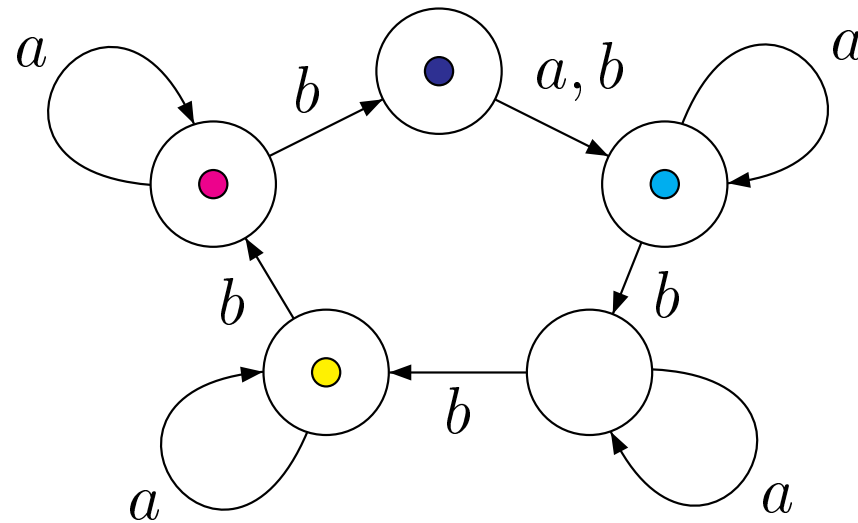

# Černý Automata

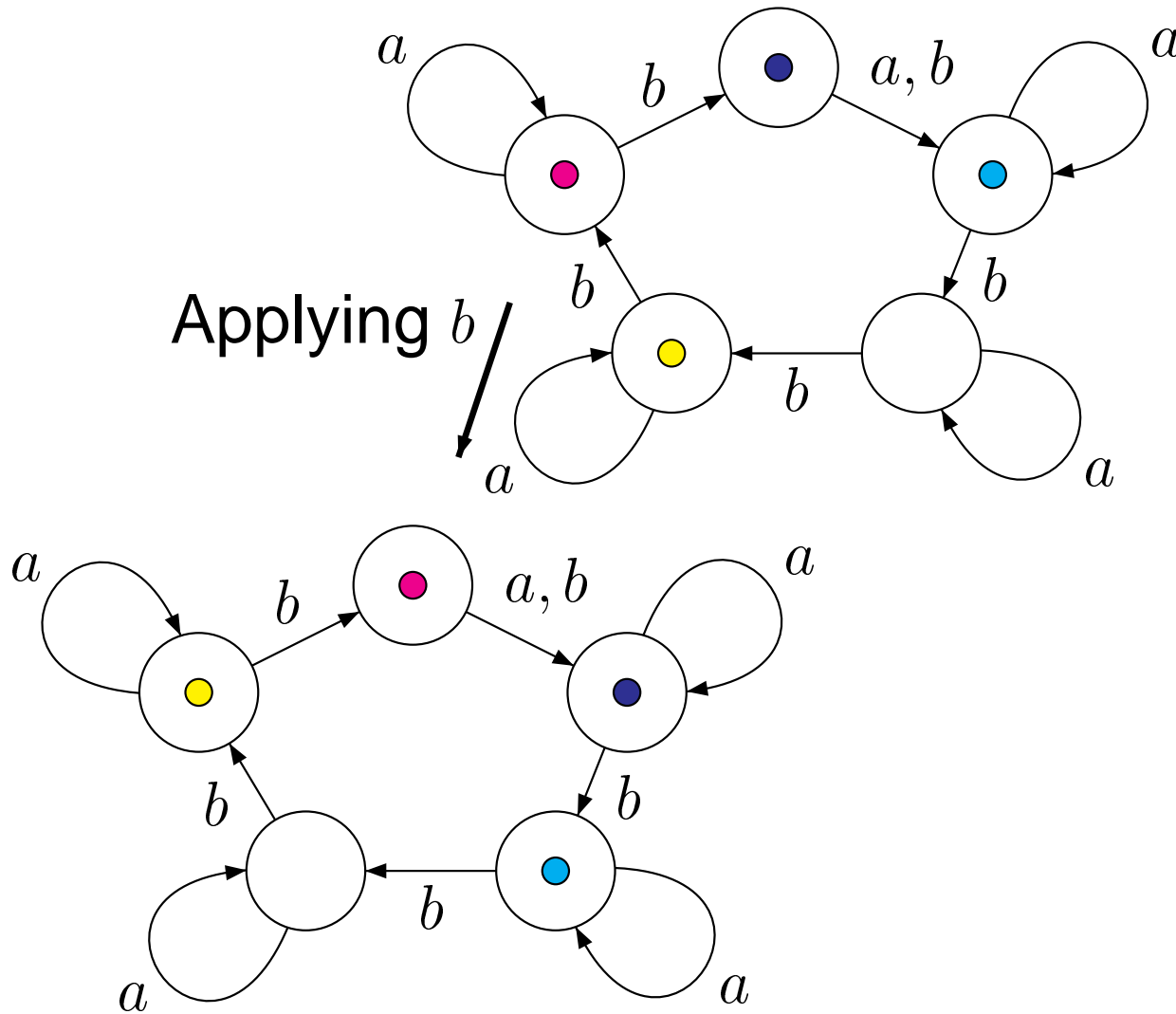

# Černý Automata

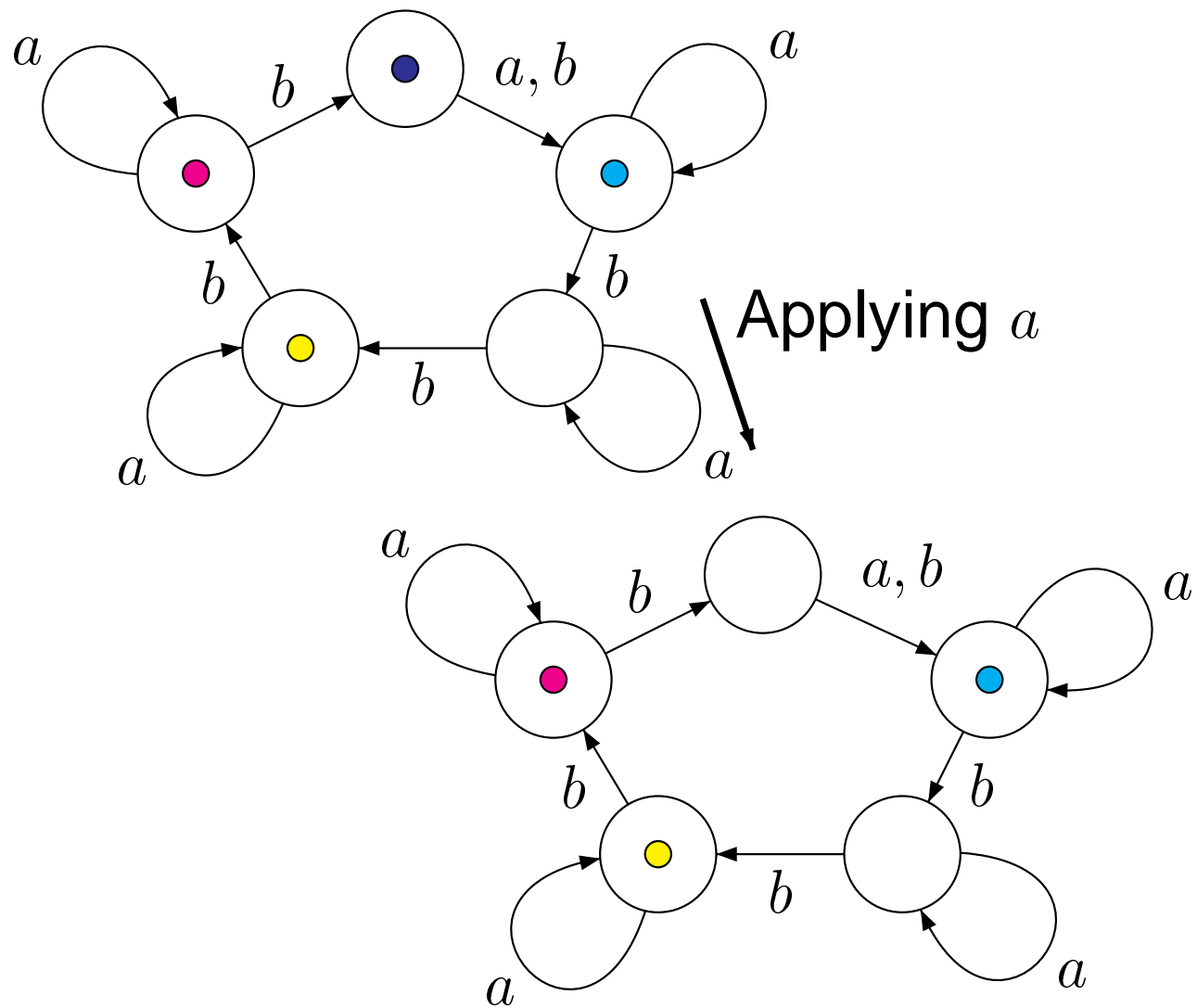

Let  $P_0$  be an initial distribution of coins,  $w$  a reset word.

Let  $P_0$  be an initial distribution of coins,  $w$  a reset word. Denote by  $P_i$  the position that arises when we apply the prefix of  $w$  of length  $i$  to the position  $P_0$ .

Let  $P_0$  be an initial distribution of coins,  $w$  a reset word. Denote by  $P_i$  the position that arises when we apply the prefix of  $w$  of length  $i$  to the position  $P_0$ . We want to define the **weight**  $\text{wg}(P_i)$  of the position such that

Let  $P_0$  be an initial distribution of coins,  $w$  a reset word. Denote by  $P_i$  the position that arises when we apply the prefix of  $w$  of length  $i$  to the position  $P_0$ . We want to define the **weight**  $\text{wg}(P_i)$  of the position such that

- (i)  $\text{wg}(P_0) \geq n(n - 1)$  and  $\text{wg}(P_{|w|}) \leq n - 1$ ;
- (ii) for each  $i = 1, \dots, |w|$ , the action of the  $i^{\text{th}}$  letter of  $w$  decreases the weight by 1 at most, that is,  $1 \geq \text{wg}(P_{i-1}) - \text{wg}(P_i)$ .

Let  $P_0$  be an initial distribution of coins,  $w$  a reset word. Denote by  $P_i$  the position that arises when we apply the prefix of  $w$  of length  $i$  to the position  $P_0$ . We want to define the **weight**  $\text{wg}(P_i)$  of the position such that

- (i)  $\text{wg}(P_0) \geq n(n - 1)$  and  $\text{wg}(P_{|w|}) \leq n - 1$ ;
- (ii) for each  $i = 1, \dots, |w|$ , the action of the  $i^{\text{th}}$  letter of  $w$  decreases the weight by 1 at most, that is,  $1 \geq \text{wg}(P_{i-1}) - \text{wg}(P_i)$ .

$$\text{Then } |w| = \sum_{i=1}^{|w|} 1 \geq \sum_{i=1}^{|w|} (\text{wg}(P_{i-1}) - \text{wg}(P_i)) =$$

$$\text{wg}(P_0) - \text{wg}(P_{|w|}) \geq n(n - 1) - (n - 1) = (n - 1)^2.$$

The trick consists in letting the weight of each coin depend on its relative location w.r.t. the golden coin.

The trick consists in letting the weight of each coin depend on its relative location w.r.t. the golden coin. If a coin  $C$  is present in a position  $P_i$ , let  $s_i(C)$  be the state covered with  $C$  in this position. We define the *weight of  $C$  in the position  $P_i$*  as

$$\text{wg}(C, P_i) = n \cdot d_i(C) + m_i(C)$$

where  $m_i(C)$  is the residue of  $n - s_i(C)$  modulo  $n$  and  $d_i(C)$  is the number of steps from  $s_i(C)$  to  $s_i(G)$  in the ‘main circle’ of our automaton. (Recall that  $G$  stands for the golden coin  $G$  which is present in all positions.)

The trick consists in letting the weight of each coin depend on its relative location w.r.t. the golden coin. If a coin  $C$  is present in a position  $P_i$ , let  $s_i(C)$  be the state covered with  $C$  in this position. We define the *weight of  $C$  in the position  $P_i$*  as

$$\text{wg}(C, P_i) = n \cdot d_i(C) + m_i(C)$$

where  $m_i(C)$  is the residue of  $n - s_i(C)$  modulo  $n$  and  $d_i(C)$  is the number of steps from  $s_i(C)$  to  $s_i(G)$  in the ‘main circle’ of our automaton. (Recall that  $G$  stands for the golden coin  $G$  which is present in all positions.) The weight of  $P_i$  is the maximum weight of the coins present in this position.

# Černý Automata

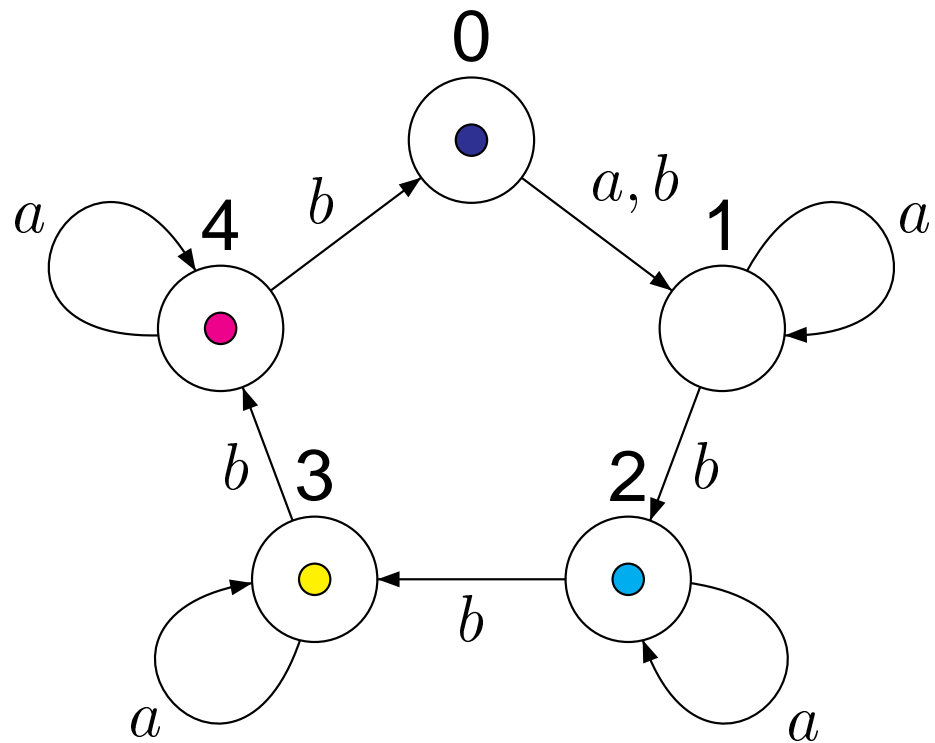

# Černý Automata

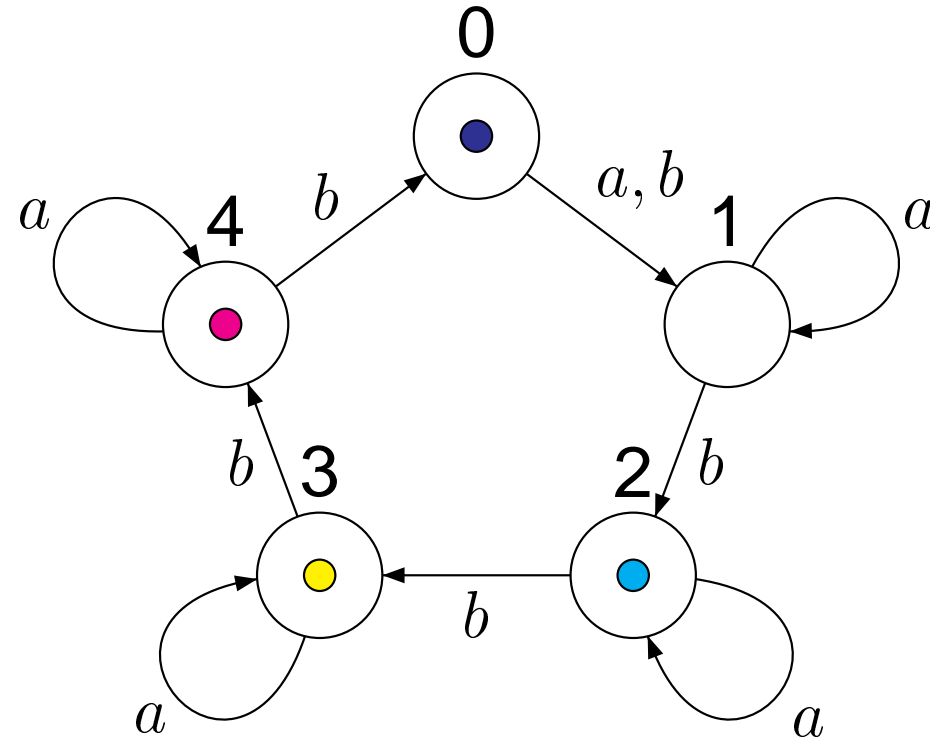

Assume that the yellow coin is the golden one.

# Černý Automata

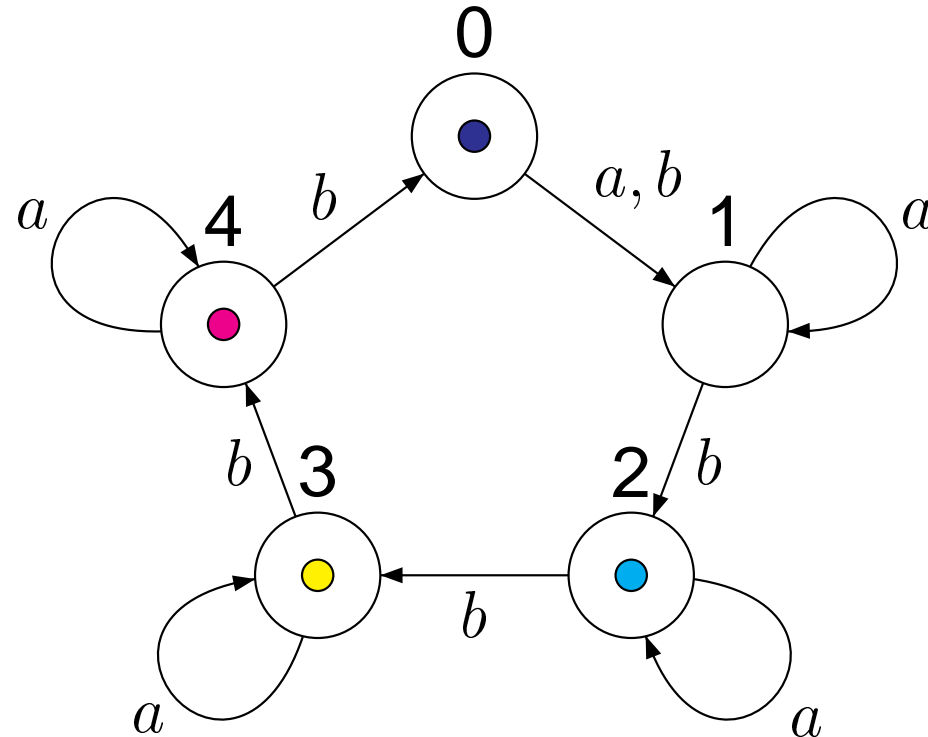

Assume that the yellow coin is the golden one. Then its weight is  $5 - 3 = 2$ .

# Černý Automata

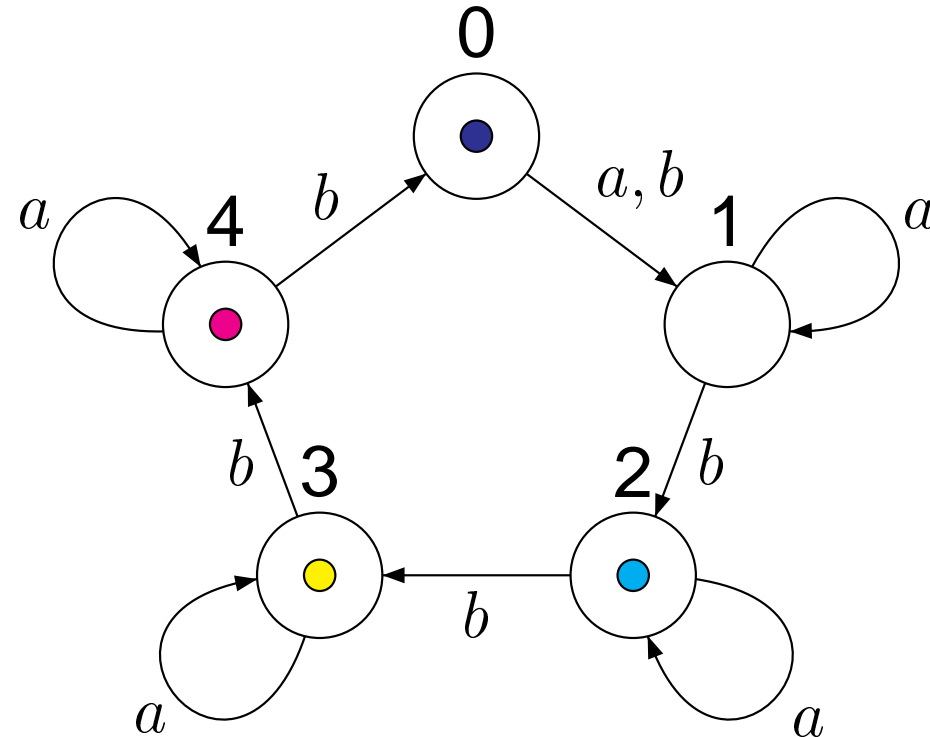

Assume that the yellow coin is the golden one. Then its weight is  $5 - 3 = 2$ . The weight of the cyan coin is  $5 \cdot 1 + (5 - 2) = 8$ .

# Černý Automata

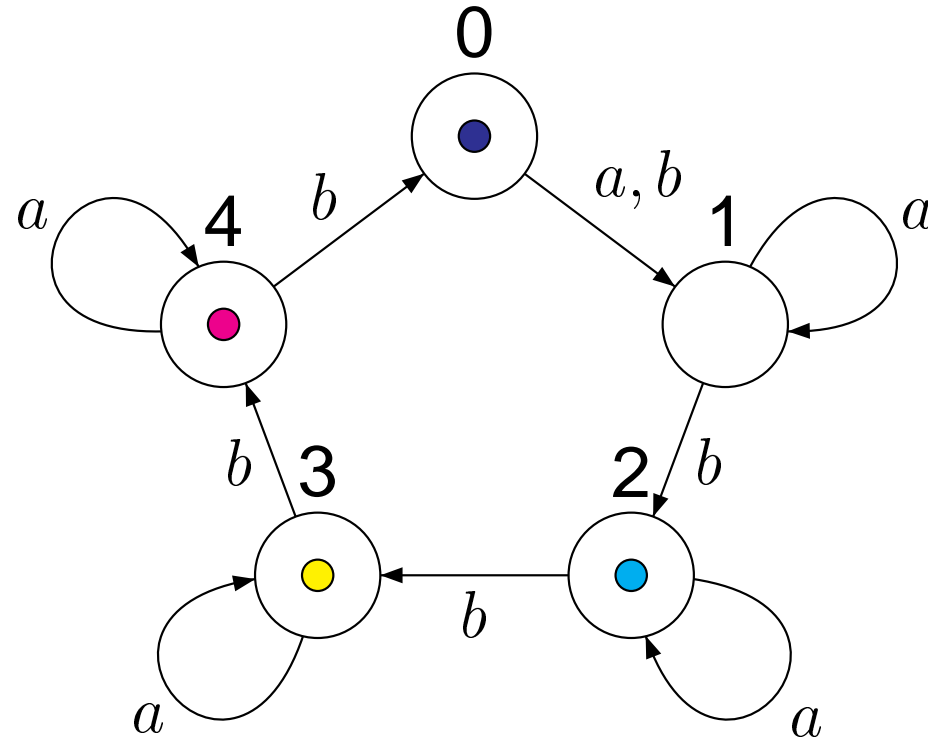

Assume that the yellow coin is the golden one. Then its weight is  $5 - 3 = 2$ . The weight of the cyan coin is  $5 \cdot 1 + (5 - 2) = 8$ . The weight of the blue coin is  $5 \cdot 3 + 0 = 15$ .

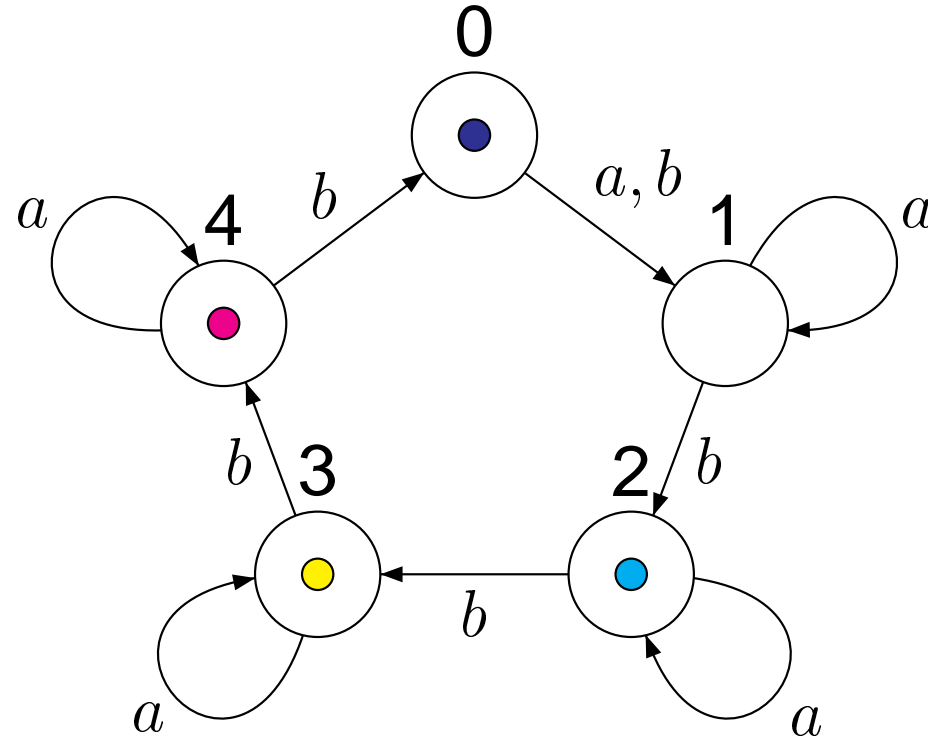

Assume that the yellow coin is the golden one. Then its weight is  $5 - 3 = 2$ . The weight of the cyan coin is  $5 \cdot 1 + (5 - 2) = 8$ . The weight of the blue coin is  $5 \cdot 3 + 0 = 15$ . The weight of the magenta coin is  $5 \cdot 4 + (5 - 4) = 21$ , and this is the weight of the position.

We have to check that our weight function satisfies the conditions

- (i)  $\text{wg}(P_0) \geq n(n - 1)$  and  $\text{wg}(P_{|w|}) \leq n - 1$ ;
- (ii)  $1 \geq \text{wg}(P_{i-1}) - \text{wg}(P_i)$  for each  $i = 1, \dots, |w|$ .

We have to check that our weight function satisfies the conditions

(i)  $\text{wg}(P_0) \geq n(n - 1)$  and  $\text{wg}(P_{|w|}) \leq n - 1$ ;

(ii)  $1 \geq \text{wg}(P_{i-1}) - \text{wg}(P_i)$  for each  $i = 1, \dots, |w|$ .

In the initial position all states are covered with coins. Consider the coin  $C$  that covers the state  $s_0(G) + 1 \pmod{n}$ , that is the state in one step clockwise after the state covered with the golden coin. Then  $d_0(C) = n - 1$  whence  $\text{wg}(C, P_0) = n \cdot (n - 1) + m_0(C) \geq n(n - 1)$ . Since the weight of a position is not less than the weight of any coin in this position, we have  $\text{wg}(P_0) \geq n(n - 1)$ .

In the final position only the golden coin  $G$  remains, whence the weight of  $P_{|w|}$  is the weight of  $G$ . Clearly,  $\text{wg}(G, P_i) = m_i(G) \leq n - 1$  for any position  $P_i$ .

In the final position only the golden coin  $G$  remains, whence the weight of  $P_{|w|}$  is the weight of  $G$ . Clearly,  $\text{wg}(G, P_i) = m_i(G) \leq n - 1$  for any position  $P_i$ .

Let  $C$  be a coin of maximum weight in  $P_{i-1}$ . If the transition from  $P_{i-1}$  to  $P_i$  is caused by  $b$ , then  $d_i(C) = d_{i-1}(C)$  (because the relative location of the coins does not change) and  $m_i(C) = m_{i-1}(C) - 1$  if  $m_{i-1}(C) > 0$ , otherwise  $m_i(C) = n - 1$ .

In the final position only the golden coin  $G$  remains, whence the weight of  $P_{|w|}$  is the weight of  $G$ . Clearly,  $\text{wg}(G, P_i) = m_i(G) \leq n - 1$  for any position  $P_i$ .

Let  $C$  be a coin of maximum weight in  $P_{i-1}$ . If the transition from  $P_{i-1}$  to  $P_i$  is caused by  $b$ , then  $d_i(C) = d_{i-1}(C)$  (because the relative location of the coins does not change) and  $m_i(C) = m_{i-1}(C) - 1$  if  $m_{i-1}(C) > 0$ , otherwise  $m_i(C) = n - 1$ . We see that

$$\begin{aligned} \text{wg}(P_i) &\geq \text{wg}(C, P_i) = n \cdot d_i(C) + m_i(C) \geq \\ n \cdot d_{i-1}(C) + m_{i-1}(C) - 1 &= \text{wg}(C, P_{i-1}) - 1 = \text{wg}(P_{i-1}) - 1. \end{aligned}$$

Suppose the transition from  $P_{i-1}$  to  $P_i$  is caused by  $a$ .

If  $s_{i-1}(C) \neq 0$ , then  $m_i(C) = m_{i-1}(C)$  and  $d_i(C) = d_{i-1}(C)$

if  $s_{i-1}(G) \neq 0$ , otherwise  $d_i(C) = d_{i-1}(C) + 1$ .

Suppose the transition from  $P_{i-1}$  to  $P_i$  is caused by  $a$ .  
If  $s_{i-1}(C) \neq 0$ , then  $m_i(C) = m_{i-1}(C)$  and  $d_i(C) = d_{i-1}(C)$   
if  $s_{i-1}(G) \neq 0$ , otherwise  $d_i(C) = d_{i-1}(C) + 1$ . Thus, the  
transition from  $P_{i-1}$  to  $P_i$  cannot decrease the weight.

Suppose the transition from  $P_{i-1}$  to  $P_i$  is caused by  $a$ .  
If  $s_{i-1}(C) \neq 0$ , then  $m_i(C) = m_{i-1}(C)$  and  $d_i(C) = d_{i-1}(C)$   
if  $s_{i-1}(G) \neq 0$ , otherwise  $d_i(C) = d_{i-1}(C) + 1$ . Thus, the  
transition from  $P_{i-1}$  to  $P_i$  cannot decrease the weight.

Assume that  $C$  covers 0 in  $P_{i-1}$ . Then in  $P_i$  the state 1  
holds a coin  $C'$  (which may or may not coincide with  
 $C$ ). In  $P_{i-1}$  the golden coin  $G$  does not cover 0 whence  
it does not move and  $d_i(C') = d_{i-1}(C) - 1$ .

Suppose the transition from  $P_{i-1}$  to  $P_i$  is caused by  $a$ .  
If  $s_{i-1}(C) \neq 0$ , then  $m_i(C) = m_{i-1}(C)$  and  $d_i(C) = d_{i-1}(C)$   
if  $s_{i-1}(G) \neq 0$ , otherwise  $d_i(C) = d_{i-1}(C) + 1$ . Thus, the  
transition from  $P_{i-1}$  to  $P_i$  cannot decrease the weight.

Assume that  $C$  covers 0 in  $P_{i-1}$ . Then in  $P_i$  the state 1  
holds a coin  $C'$  (which may or may not coincide with  
 $C$ ). In  $P_{i-1}$  the golden coin  $G$  does not cover 0 whence  
it does not move and  $d_i(C') = d_{i-1}(C) - 1$ . Therefore

$$\begin{aligned} \text{wg}(P_i) &\geq \text{wg}(C', P_i) = n \cdot d_i(C') + n - 1 = n \cdot (d_{i-1}(C) - 1) + n - 1 \\ &= n \cdot d_{i-1}(C) - 1 = \text{wg}(C, P_{i-1}) - 1 = \text{wg}(P_{i-1}) - 1. \end{aligned}$$

# Ananichev's Example

The proof for Ananichev's example uses the same underlying idea but a more sophisticated weight function that is defined via pairs of coins.

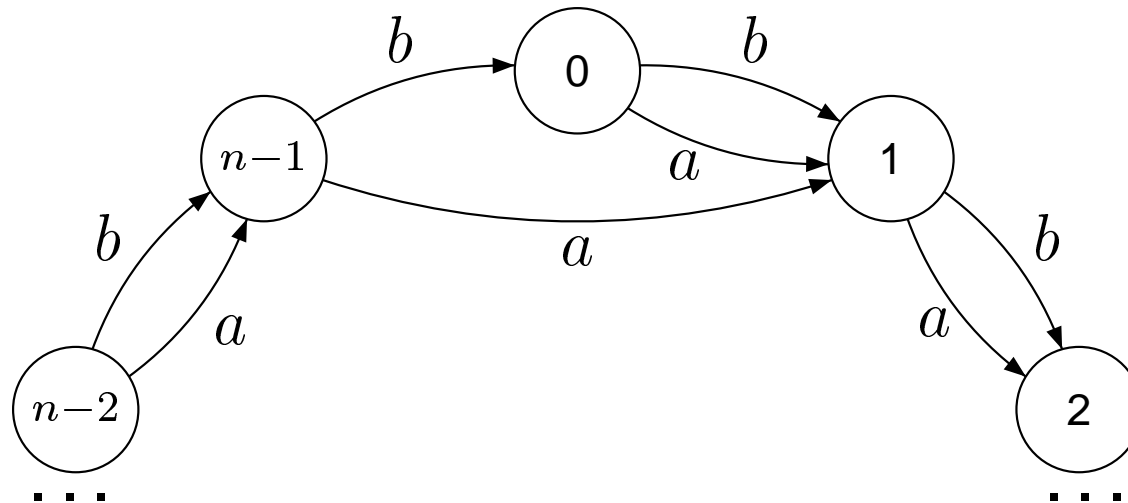

# *Road Coloring*

---

We think of an automaton as of a scheme of a transport network in which arrows correspond to roads and labels are treated as colors of the roads.

# Road Coloring

We think of an automaton as of a scheme of a transport network in which arrows correspond to roads and labels are treated as colors of the roads.

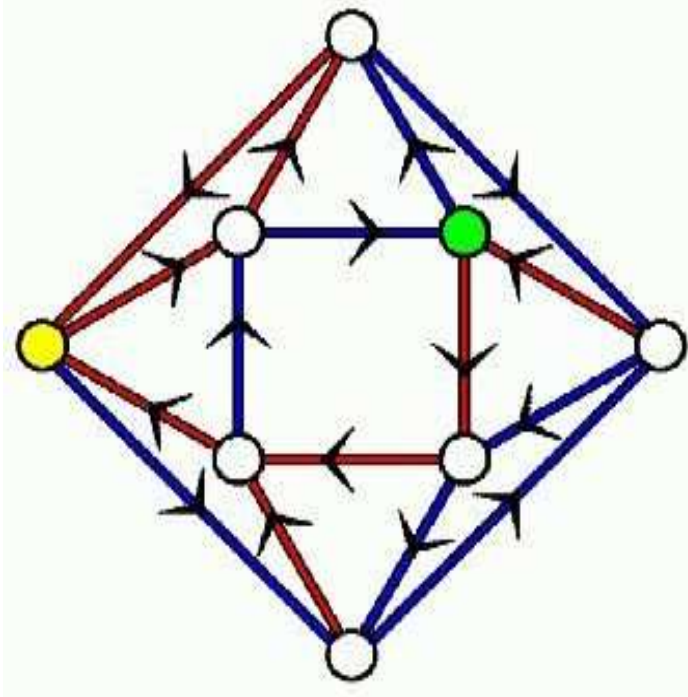

# Road Coloring

We think of an automaton as of a scheme of a transport network in which arrows correspond to roads and labels are treated as colors of the roads.

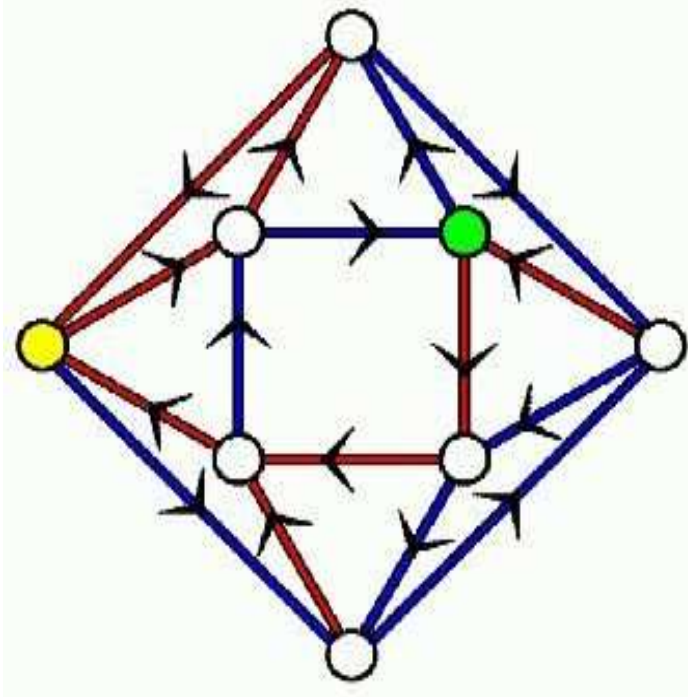

Then for each node  $N$  there is a sequence of colors that brings one to  $N$  from anywhere.

# Road Coloring

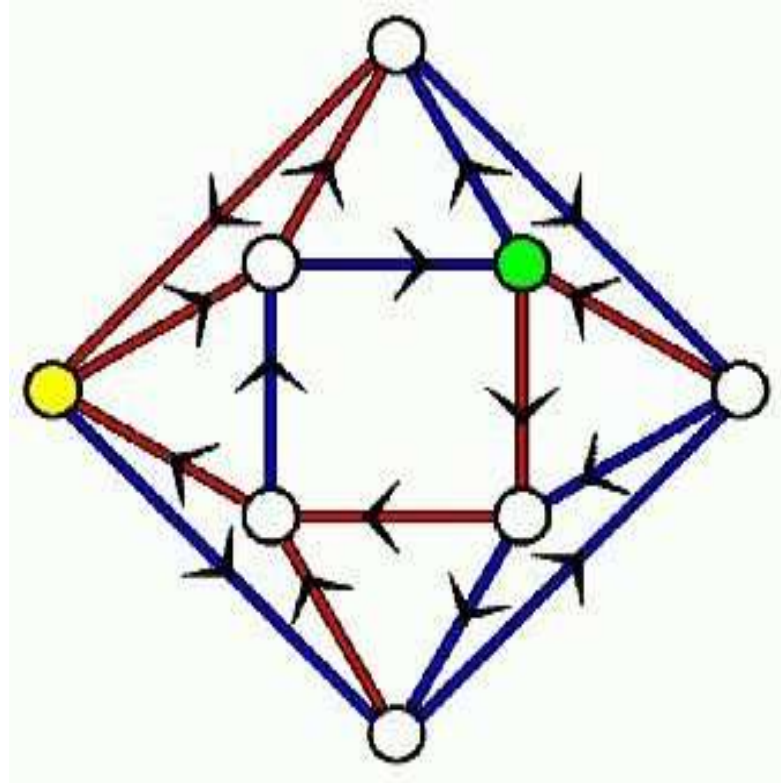

# Road Coloring

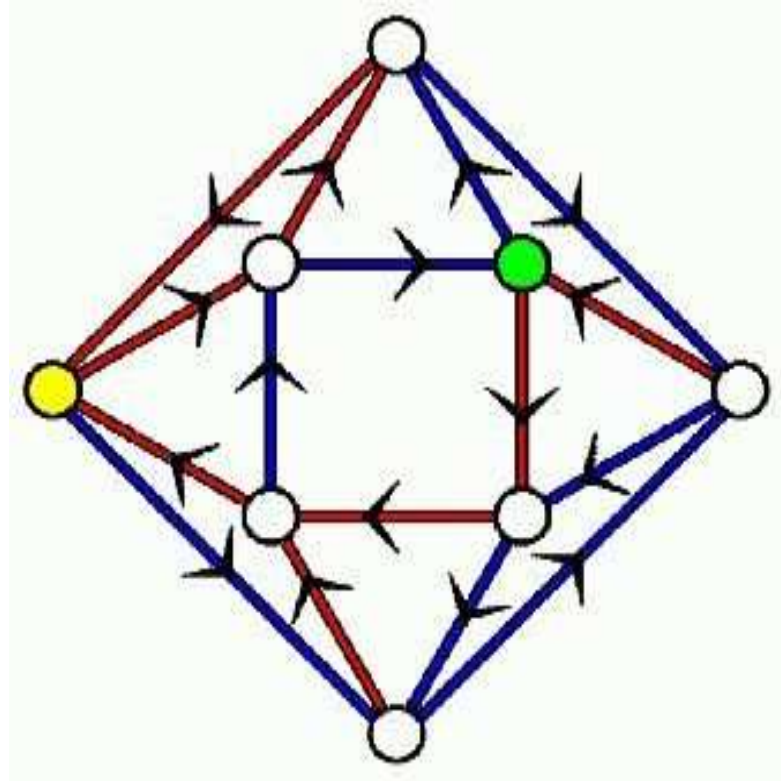

For the green node:  
blue-blue-red-blue-blue-red-blue-blue-red.

# Road Coloring

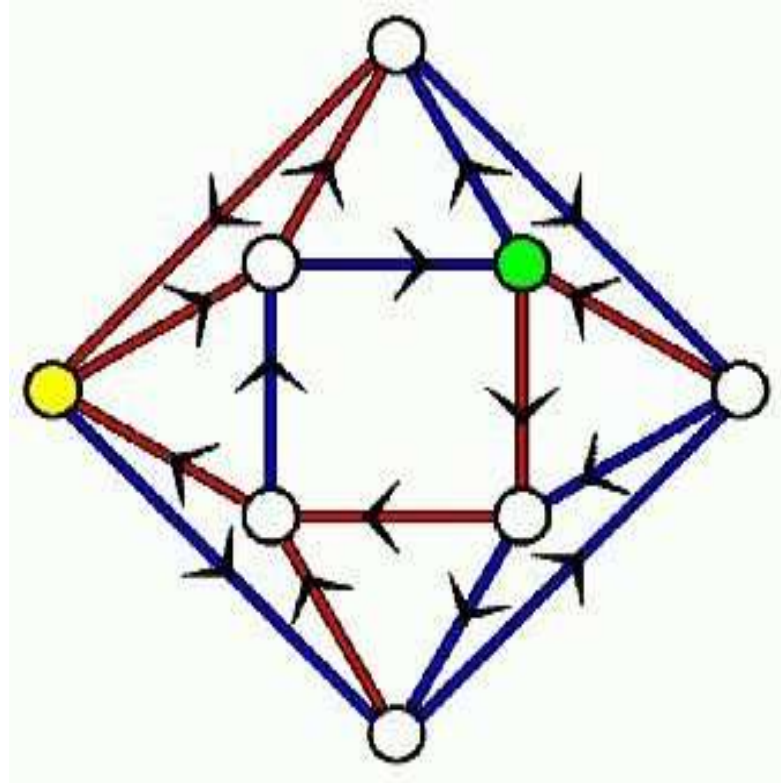

For the green node:  
blue-blue-red-blue-blue-red-blue-blue-red.

For the yellow node:  
blue-red-red-blue-red-red-blue-red-red.

# *Road Coloring*

---

From the viewpoint of transportation network the constant out-degree condition does not seem to be natural.

# *Road Coloring*

---

From the viewpoint of transportation network the constant out-degree condition does not seem to be natural. We rather want to find a synchronizing coloring for arbitrary strongly connected primitive digraph  $\Gamma$ , the number of colors being the maximal out-degree of  $\Gamma$ .

# *Road Coloring*

---

From the viewpoint of transportation network the constant out-degree condition does not seem to be natural. We rather want to find a synchronizing coloring for arbitrary strongly connected primitive digraph  $\Gamma$ , the number of colors being the maximal out-degree of  $\Gamma$ . This can be achieved if we allow to assign multiple colors to some edges leaving from vertices with non-maximal out-degree.

From the viewpoint of transportation network the constant out-degree condition does not seem to be natural. We rather want to find a synchronizing coloring for arbitrary strongly connected primitive digraph  $\Gamma$ , the number of colors being the maximal out-degree of  $\Gamma$ . This can be achieved if we allow to assign multiple colors to some edges leaving from vertices with non-maximal out-degree.

Clearly, Trahtman's theorem holds true in this setting and may be stated as follows:

**every strongly connected primitive digraph admits a synchronizing coloring.**

# Ananichev's Example

For an illustration, Ananichev's example can be obtained this way from the following digraph:

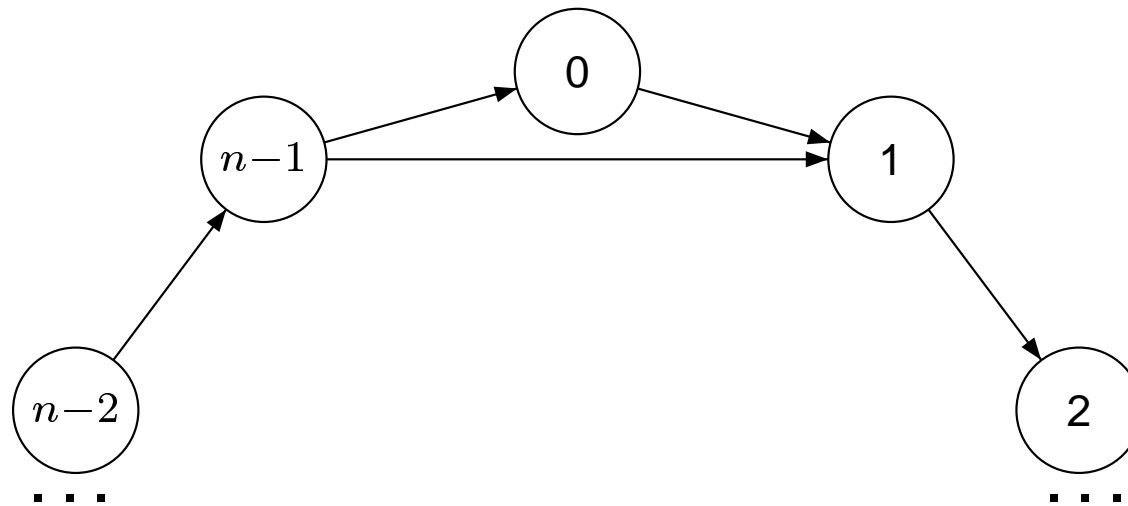

# Ananichev's Example

For an illustration, Ananichev's example can be obtained this way from the following digraph:

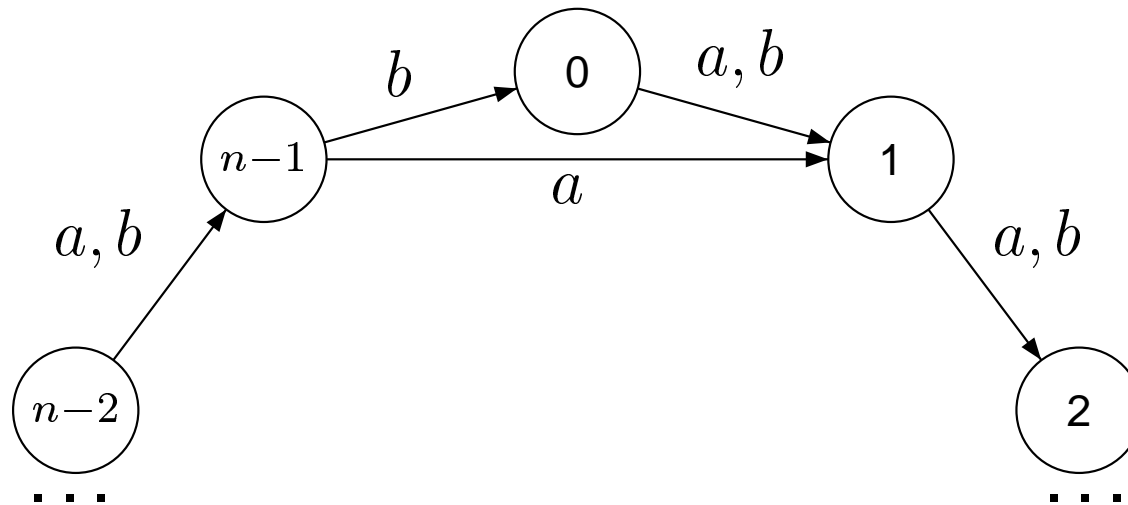

# Reverse Game

We can reverse the graph and play the reverse game in which only one vertex holds a coin in the beginning and coins multiply whenever sliding from a vertex with out-degree more than 1.

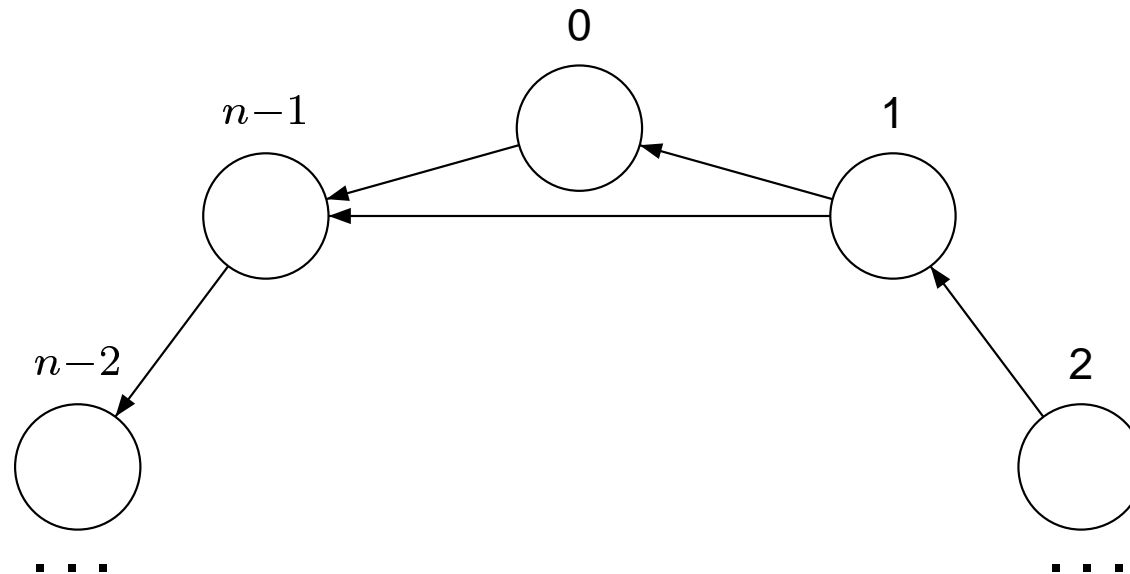

# Reverse Game

We can reverse the graph and play the reverse game in which only one vertex holds a coin in the beginning and coins multiply whenever sliding from a vertex with out-degree more than 1.

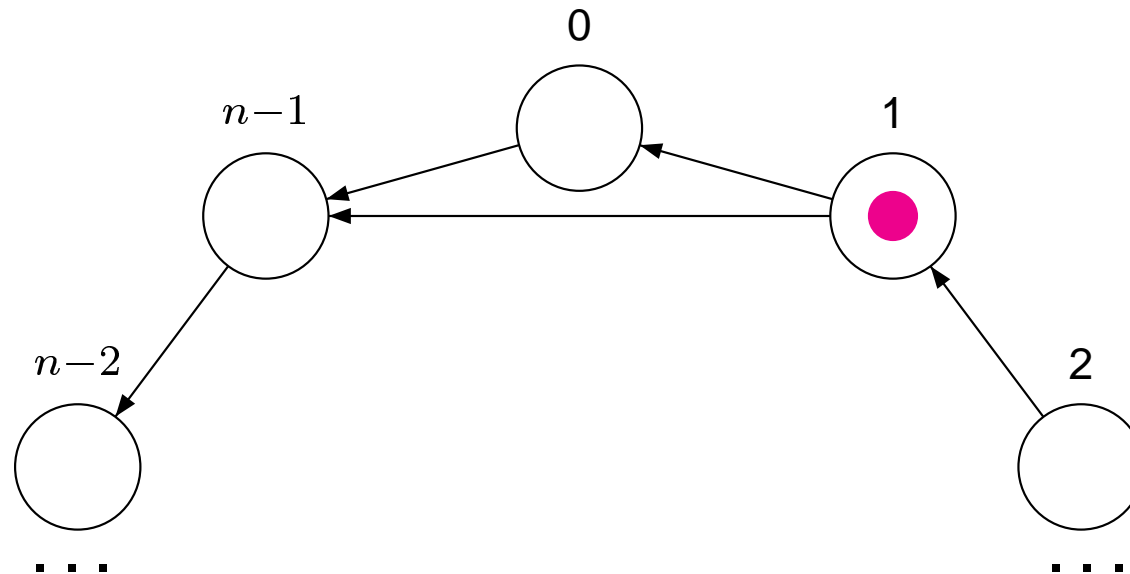

# Reverse Game

We can reverse the graph and play the reverse game in which only one vertex holds a coin in the beginning and coins multiply whenever sliding from a vertex with out-degree more than 1.

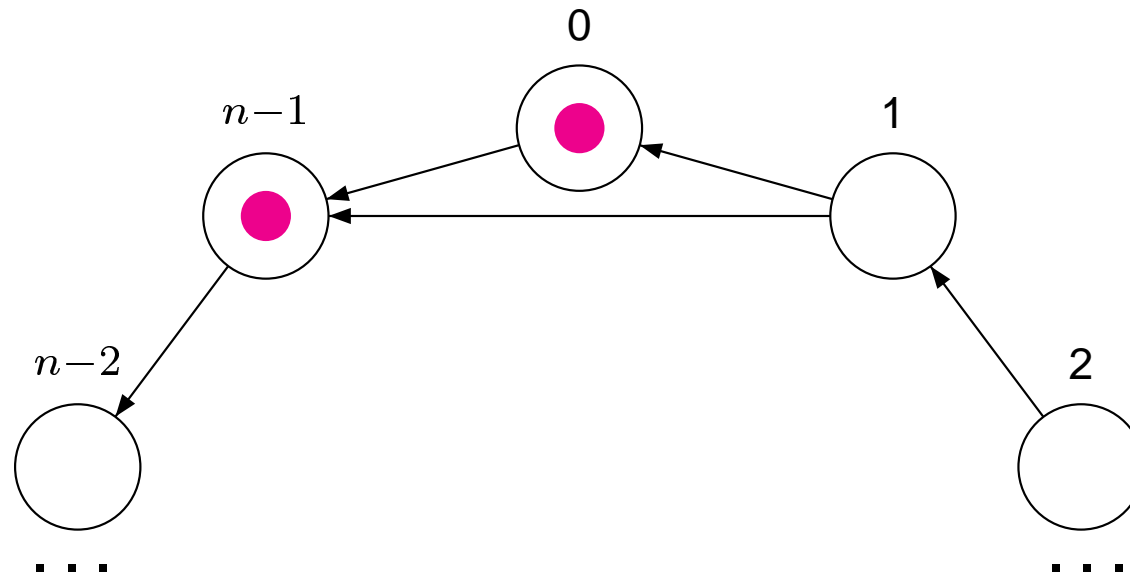

# Reverse Game

We can reverse the graph and play the reverse game in which only one vertex holds a coin in the beginning and coins multiply whenever sliding from a vertex with out-degree more than 1.

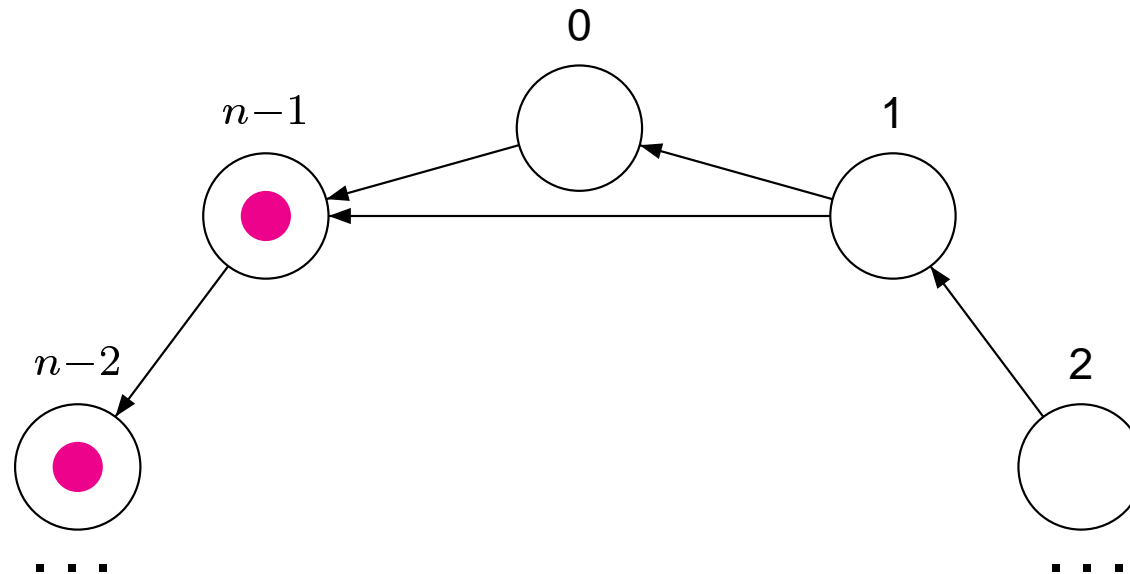

## *Reverse Game*

---

Clearly, the minimum length of reset words for synchronizing colorings of a given strongly connected primitive digraph is related to the number of moves in the reverse game that are necessary to spread coins over all vertices of the graph.

Clearly, the minimum length of reset words for synchronizing colorings of a given strongly connected primitive digraph is related to the number of moves in the reverse game that are necessary to spread coins over all vertices of the graph.

The latter number is well known in the Perron–Frobenius theory of non-negative matrices.

Clearly, the minimum length of reset words for synchronizing colorings of a given strongly connected primitive digraph is related to the number of moves in the reverse game that are necessary to spread coins over all vertices of the graph.

The latter number is well known in the Perron–Frobenius theory of non-negative matrices. Recall that a real non-negative matrix  $A$  is said to be *primitive* if  $A^k$  is positive for some  $k$ .

Clearly, the minimum length of reset words for synchronizing colorings of a given strongly connected primitive digraph is related to the number of moves in the reverse game that are necessary to spread coins over all vertices of the graph.

The latter number is well known in the Perron–Frobenius theory of non-negative matrices. Recall that a real non-negative matrix  $A$  is said to be *primitive* if  $A^k$  is positive for some  $k$ . It can be verified that this property of  $A$  is equivalent to the fact that the digraph  $\Gamma(A)$  in which  $i \rightarrow j$  iff  $a_{ij} > 0$  is strongly connected and primitive in our sense.

Clearly, the minimum length of reset words for synchronizing colorings of a given strongly connected primitive digraph is related to the number of moves in the reverse game that are necessary to spread coins over all vertices of the graph.

The latter number is well known in the Perron–Frobenius theory of non-negative matrices. Recall that a real non-negative matrix  $A$  is said to be *primitive* if  $A^k$  is positive for some  $k$ . It can be verified that this property of  $A$  is equivalent to the fact that the digraph  $\Gamma(A)$  in which  $i \rightarrow j$  iff  $a_{ij} > 0$  is strongly connected and primitive in our sense. Our number is nothing but the least  $k$  such that  $A^k$  is positive.

# *Wielandt's Theorem*

---

Wielandt (1950) proved that if  $A$  is a primitive  $n \times n$ -matrix, then  $A^{n^2-2n+2}$  is positive and gave an example when this bound is achieved.

# Wielandt's Theorem

Wielandt (1950) proved that if  $A$  is a primitive  $n \times n$ -matrix, then  $A^{n^2-2n+2}$  is positive and gave an example when this bound is achieved. The example is, of course, nothing but the matrix of the digraph from Ananichev's example.

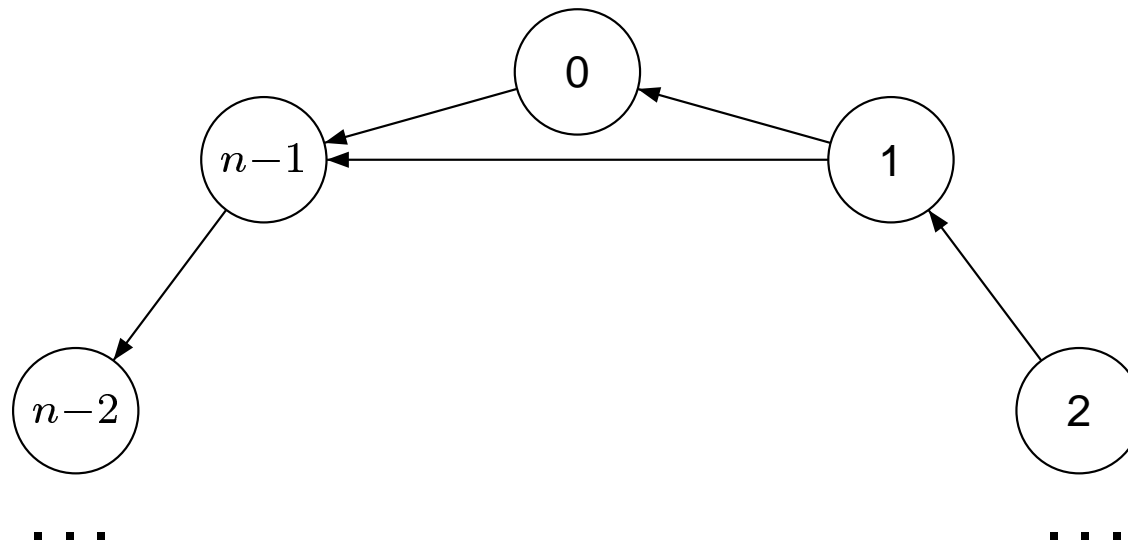

# *Wielandt's Theorem*

---

Why do the results differ? ( $n^2 - 2n + 2$  in Wielandt's theorem,  $n^2 - 3n + 3$  in Ananichev's proof).

# Wielandt's Theorem

---

Why do the results differ? ( $n^2 - 2n + 2$  in Wielandt's theorem,  $n^2 - 3n + 3$  in Ananichev's proof). Because settings are different: in Wielandt's theorem coins spread from an arbitrary vertex, while we are interested in spreading coins from the best possible vertex (vertex 1 in our case).

## Wielandt's Theorem

---

Why do the results differ? ( $n^2 - 2n + 2$  in Wielandt's theorem,  $n^2 - 3n + 3$  in Ananichev's proof). Because settings are different: in Wielandt's theorem coins spread from an arbitrary vertex, while we are interested in spreading coins from the best possible vertex (vertex 1 in our case). Observe that  $(n^2 - 2n + 2) - (n^2 - 3n + 3) = n - 1$  so Wielandt's example follows from Ananichev's one.

# Wielandt's Theorem

Why do the results differ? ( $n^2 - 2n + 2$  in Wielandt's theorem,  $n^2 - 3n + 3$  in Ananichev's proof). Because settings are different: in Wielandt's theorem coins spread from an arbitrary vertex, while we are interested in spreading coins from the best possible vertex (vertex 1 in our case). Observe that  $(n^2 - 2n + 2) - (n^2 - 3n + 3) = n - 1$  so Wielandt's example follows from Ananichev's one.

We conjecture that  $n^2 - 3n + 3$  is the **exact value** in the hybrid Černý/Road Coloring problem.

# Wielandt's Theorem

Why do the results differ? ( $n^2 - 2n + 2$  in Wielandt's theorem,  $n^2 - 3n + 3$  in Ananichev's proof). Because settings are different: in Wielandt's theorem coins spread from an arbitrary vertex, while we are interested in spreading coins from the best possible vertex (vertex 1 in our case). Observe that  $(n^2 - 2n + 2) - (n^2 - 3n + 3) = n - 1$  so Wielandt's example follows from Ananichev's one.

We conjecture that  $n^2 - 3n + 3$  is the **exact value** in the hybrid Černý/Road Coloring problem. Though Wielandt's theorem doesn't immediately applies here, it gives a very strong supporting evidence for this conjecture as well as the original Černý conjecture.

**Thanks**

Thank you for your kind attention!

**Thanks**

Thank you for your kind attention!  
Thank you for your kind attention!

Thank you for your kind attention!  
Thank you for your kind attention!

**Thanks**

Thank you very much for your kind attention!

Thank you very much for your kind attention!

Thank you very much for your kind attention!